

# NEW PRODUCT NEWS

## TOPMINI



**3 New Holder Types Introduced to the Product Line:  
SLEEVE Holder, Y-AXIS Holder and SHIFT Holder  
for Swiss Type Automatic Lathes**



## KEY POINT

The TOPMINI product line has been expanded with the introduction of three new holder types: a new SLEEVE holder, Y-AXIS holder and SHIFT holder.

The **TOPMINI SLEEVE holder** is designed to be mounted on the rear tool post for external machining. As such, it eliminates the shortage of tools on the tool post when machining complex geometries. Not only does the T-BURST holder enable increased tool life and superior chip control, it is available in a variety of shank sizes for all Swiss type automatic lathes.

Unlike conventional holders, the **Y-AXIS holder** mounts to the tool post so the upper side of the insert faces downwards for more effective chip evacuation as chips easily eject downwards without interference during machining. An additional advantage of the Y-AXIS holder is improved rigidity due to the fact that the holder is mounted in the same direction of the workpiece's rotation realizing high precision and even more stable machining. It is optimally designed for difficult-to-cut materials such as aluminum, low carbon steel as well as stainless steel. The T-BURST type holder is also available as a Y-AXIS holder.

The **SHIFT holder** is an unconventionally shaped holder which completes finishing applications without retreating to the workpiece's guide bush after the roughing stage. A further benefit of the SHIFT holder design is that the extra space, between the holder and the workpiece, ensures easier chip removal making it suitable for the machining of thin and long workpieces in Swiss type automatic lathes.

For additional technical information, please contact the relevant product manager.

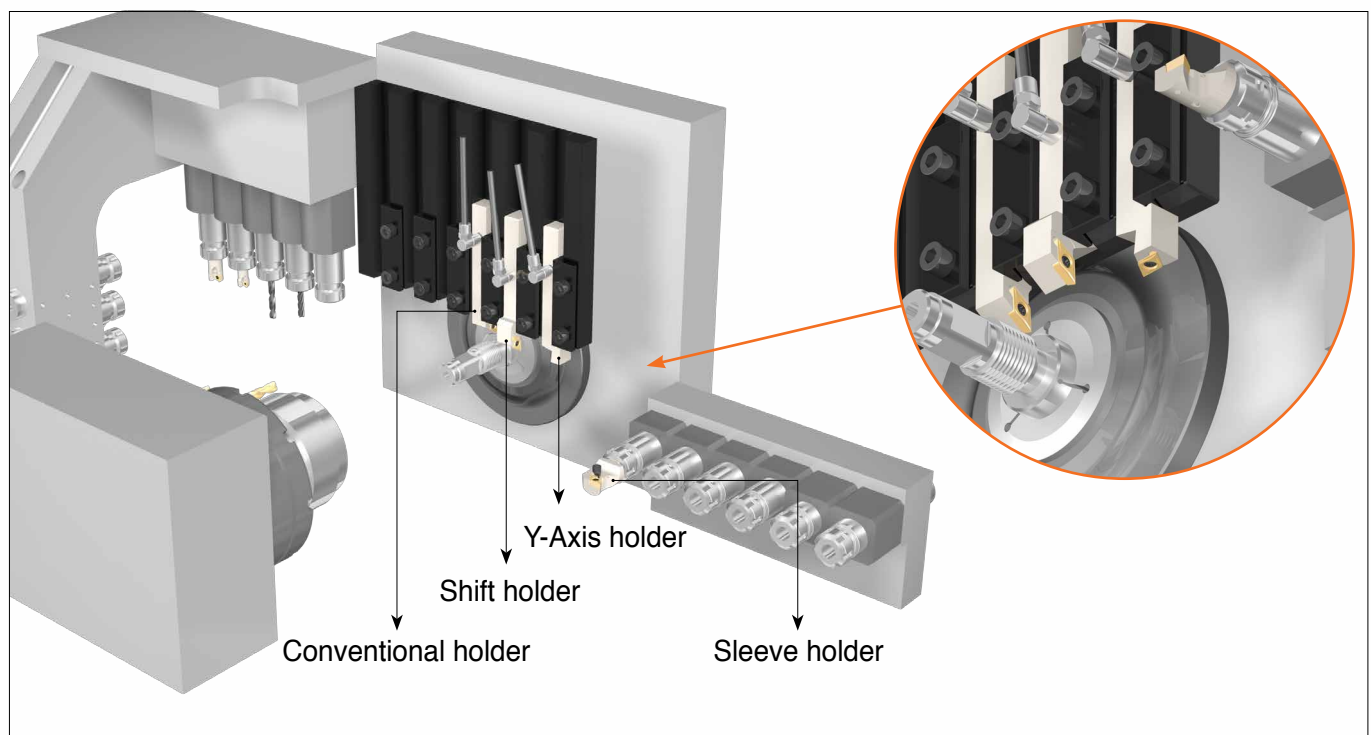

## Features

### SLEEVE holder

- Designed to machine the workpiece's outer diameter as it mounts to the rear tool post
- Eliminates the shortage of tool posts when processing complex shapes
- Increased tool life and excellent chip control for T-BURST specific applications
- Available in all shank sizes for Swiss type automatic lathes

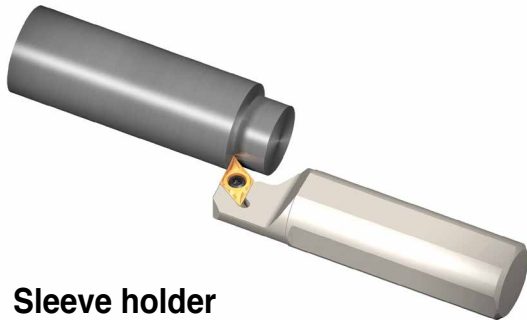

Sleeve holder

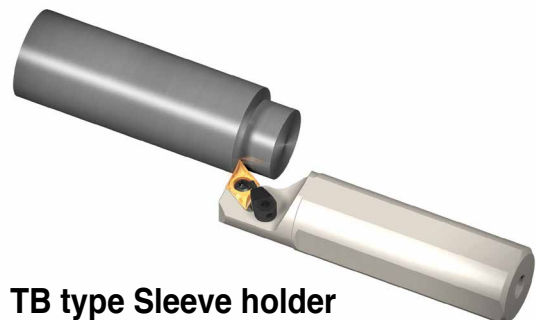

TB type Sleeve holder

### Y-AXIS holder

- Smooth chip evacuation as swarf falls downwards during machining
- Improved holder rigidity for better dimensional accuracy and stable machining
- Suitable for the machining of aluminum, low carbon steel and stainless steel
- T-BURST type holder is also available as a Y-Axis type

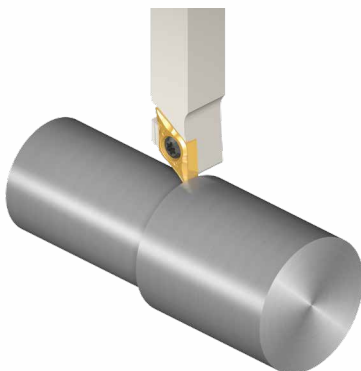

Conventional holder

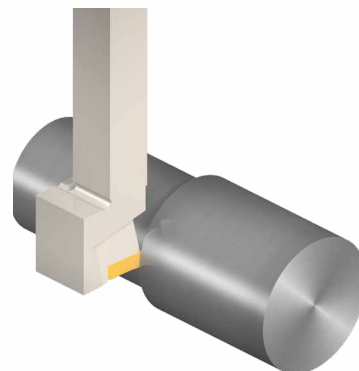

Y-AXIS holder

## SHIFT holder

- Elimination of guide bush retraction stage completes finishing applications more quickly
- Unconventional design allows for extra space between the holder and the workpiece for smoother chip evacuation
- Suitable for the machining of thin and long workpieces in Swiss type automatic lathes

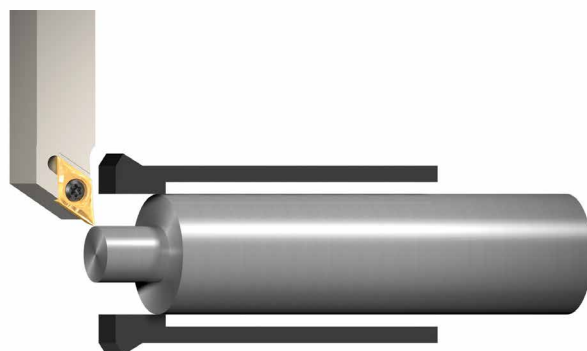

Conventional holder

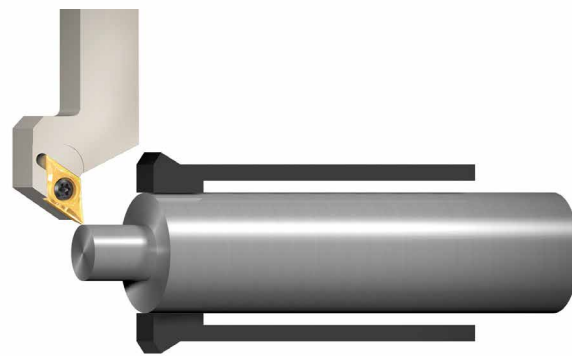

SHIFT holder



# TMS-SCLCL

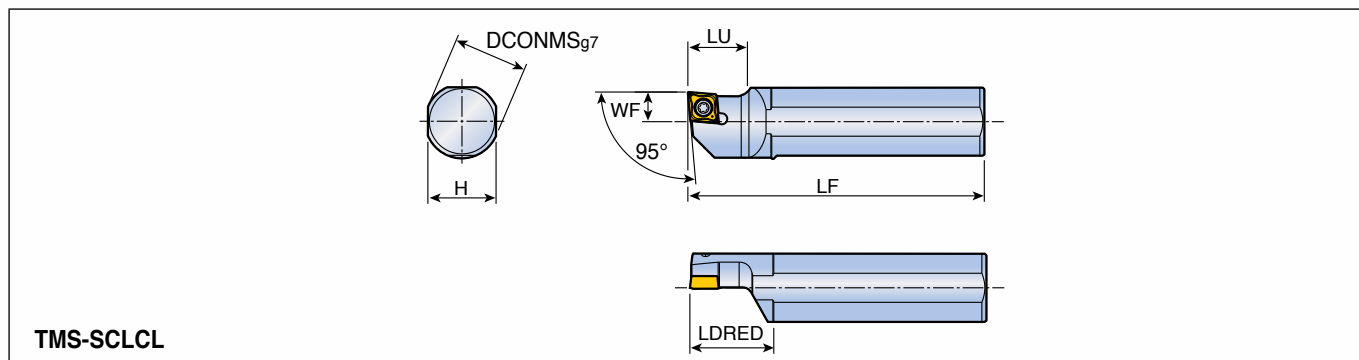

## Sleeve holder

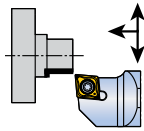

TMS-SCLCL

Approach angle	Designation	Dimension (mm)						Insert
		DCONMS	H	LF	LU	LDRED	WF	
95° 	<b>TMS- 19.05H SCLCL 09</b>	19.05	17	100	20	28	10	CC...T 09T3...
	<b>20H SCLCL 09</b>	20	18	100	20	28	10	
	<b>22H SCLCL 09</b>	22	20	100	20	28	10	
	<b>25H SCLCL 09</b>	25	23	100	20	28	10	

## Spare parts

Designation	Screw	Wrench				
						
<b>TMS-SCLCL</b>	SO 35080I	T 15				

# TMS-SDUCL

## Sleeve holder

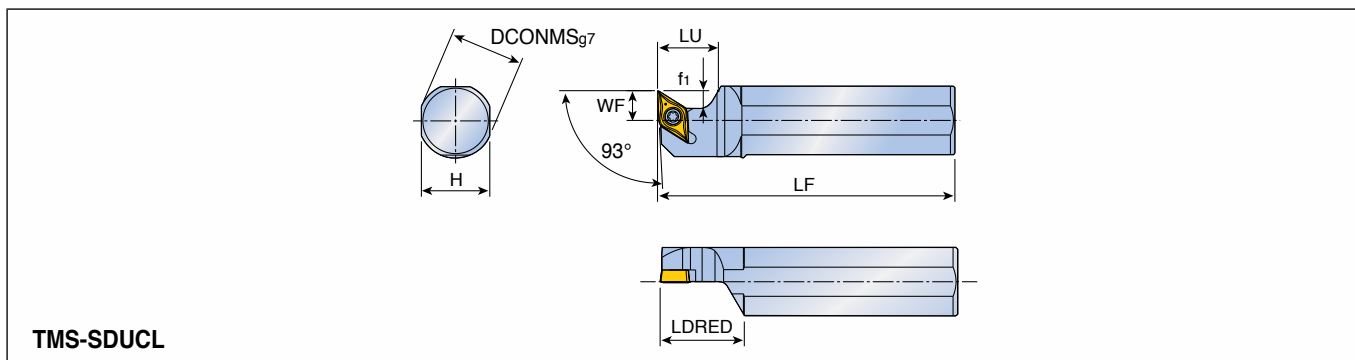

TMS-SDUCL

Approach angle	Designation	Dimension (mm)							Insert
		DCONMS	H	LF	f1	LU	LDRED	WF	
<p>93°</p> <p>30° max.</p>	<b>TMS-16X SDUCL 11</b>	16	15	85	6	20	28	10	DC...T 11T3...
	<b>19.05H SDUCL 11</b>	19.05	17	100	6	20	28	10	
	<b>20H SDUCL 11</b>	20	18	100	6	20	28	10	
	<b>22H SDUCL 11</b>	22	20	100	6	20	28	10	
	<b>25H SDUCL 11</b>	25	23	100	6	20	28	10	

## Spare parts

Designation	Screw	Wrench				
<b>TMS-SDUCL</b>	SO 35080I	T 15				

# TMS-SDUCR/L-TB

## Sleeve holder (**T-BURST**) HIGH PRESSURE

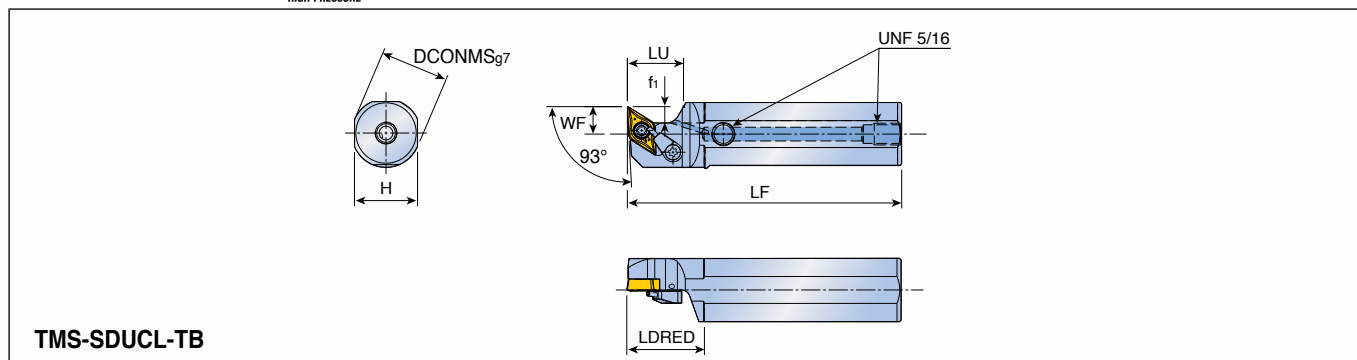

TMS-SDUCL-TB

Approach angle	Designation	Dimension (mm)							Insert
		DCONMS	H	LF	f1	LU	LDRED	WF	
 93°	<b>TMS-16X SDUCR 11-TB</b>	16	15	85	6	20	28	10	DC...T 11T3...
	<b>19.05H SDUCL 11-TB</b>	19.05	17	100	6	20	28	10	
	<b>20H SDUCL 11-TB</b>	20	18	100	6	20	28	10	
	<b>22H SDUCL 11-TB</b>	22	20	100	6	20	28	10	
	<b>25H SDUCL 11-TB</b>	25	23	100	6	20	28	10	

### Spare parts

Designation	Screw	Oil-supply unit	Plug	Wrench	
<b>TMS-SDUCR/L-TB</b>	SO 35080I	S-CU-TB	PLG 5/16 UNF	T 15	L-W 5/32

# TMS-SVUBL

## Sleeve holder

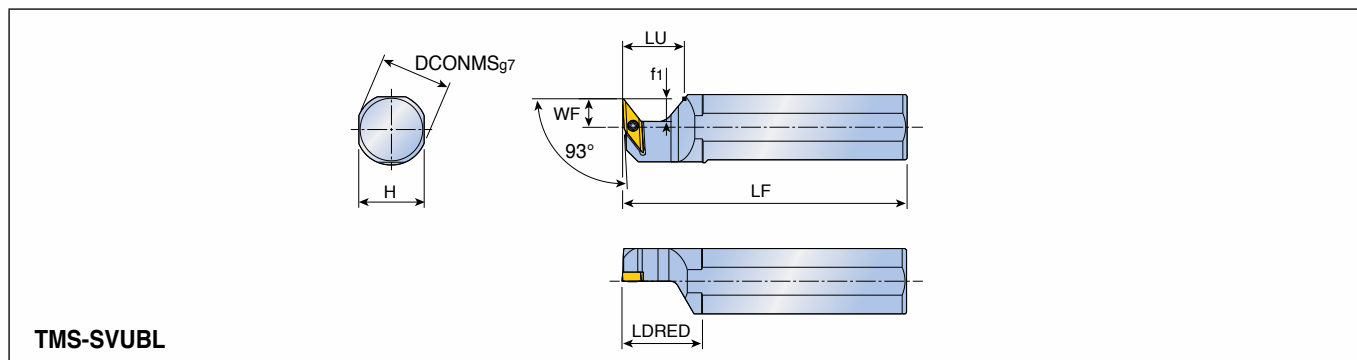

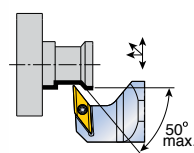

TMS-SVUBL

Approach angle	Designation	Dimension (mm)							Insert
		DCONMS	H	LF	f1	LU	LDRED	WF	
93°	<b>TMS- 19.05H SVUBL 11</b>	19.05	17	100	8	21	25	10	VB...T 1103...
	<b>20H SVUBL 11</b>	20	18	100	8	21	25	10	
	<b>22H SVUBL 11</b>	22	20	100	8	21	25	10	
	<b>25H SVUBL 11</b>	25	23	100	8	21	25	10	



## Spare parts

Designation	Screw	Wrench				
						
<b>TMS-SVUBL</b>	SO 25065I	T 7(T-7/5)				



# TMS-SVUBR/L-TB

Sleeve holder (**T-BURST**)  
HIGH PRESSURE

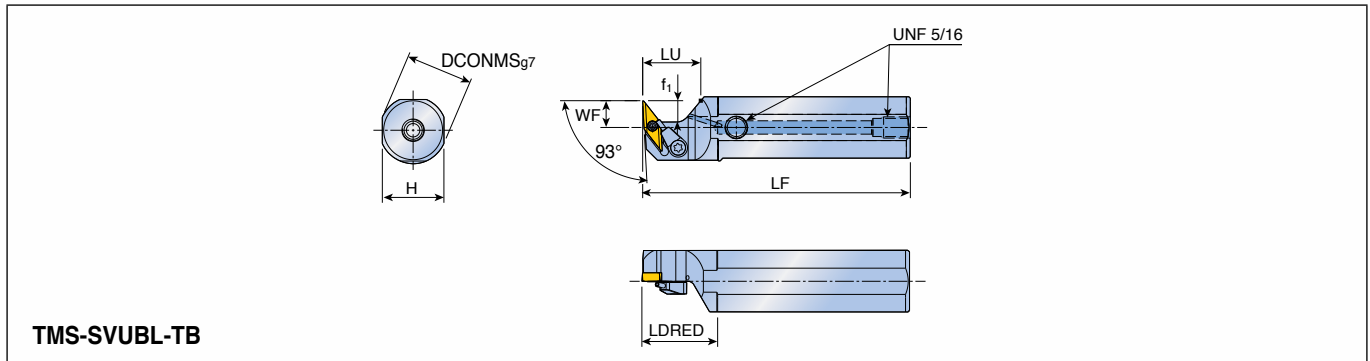

TMS-SVUBL-TB

Approach angle	Designation	Dimension (mm)							Insert
		DCONMS	H	LF	f1	LU	LDRED	WF	
93°	<b>TMS-16X SVUBR 11-TB</b>	16	15	85	8	21	25	10	VB...T 1103...
	<b>19.05H SVUBL 11-TB</b>	19.05	17	100	8	21	25	10	
	<b>20H SVUBL 11-TB</b>	20	18	100	8	21	25	10	
	<b>22H SVUBL 11-TB</b>	22	20	100	8	21	25	10	
	<b>25H SVUBL 11-TB</b>	25	23	100	8	21	25	10	

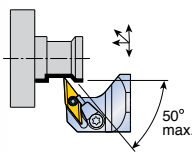

## Spare parts

Designation	Screw	Oil-supply unit	Plug	Wrench	
<b>TMS-SVUBR/L-TB</b>	SO 25065I	S-CU-TB	PLG 5/16 UNF	T 7(T-7/5)	L-W 5/32

# TMY-SDJCR

## Y-axis holder

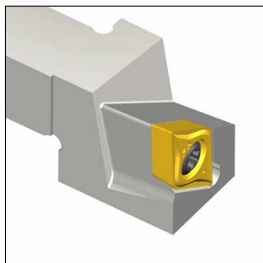

TMY-SDJCR

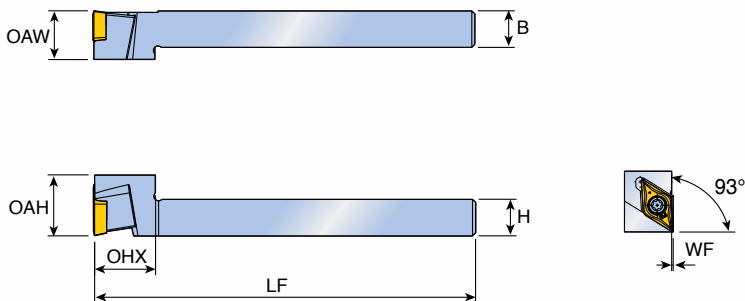

Approach angle	Designation	Dimension (mm)							Insert
		H	B	LF	OHX	OAH	OAW	WF	
93°	<b>TMY- SDJCR 1212 K11</b>	12	12	125	20	20	16	0	DC...T 11T3...
	<b>SDJCR 1616 K11</b>	16	16	125	20	20	16	0	

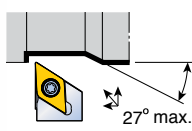

## Spare parts

Designation	Screw	Wrench				
<b>TMY-SDJCR</b>	SO 35080I	T 15				

# TMY-SDJCR-TB

## Y-axis holder (*T-BÜRST*) HIGH PRESSURE

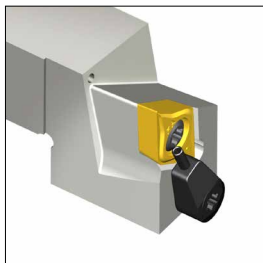

TMY-SDJCR-TB

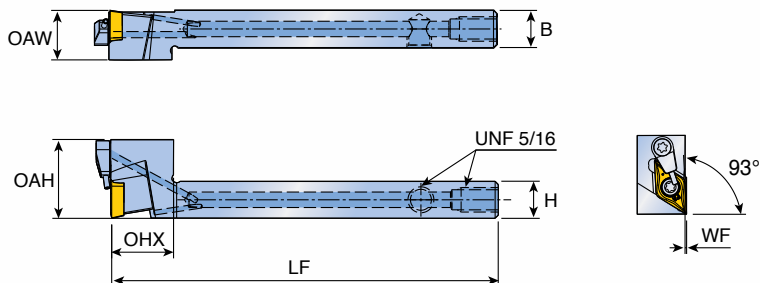

Approach angle	Designation	Dimension (mm)							Insert
		H	B	LF	OHX	OAH	OAW	WF	
93°	<b>TMY- SDJCR 1212 K11-TB</b>	12	12	125	20	25.5	16	0	DC...T 11T3...
	<b>SDJCR 1616 K11-TB</b>	16	16	125	20	25.5	16	0	

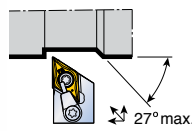

### Spare parts

Designation	Screw	Oil-supply unit	Plug	Wrench	
<b>TMY-SDJCR-TB</b>	SO 35080I	S-CU-TB	PLG 5/16 UNF	T 15	L-W 5/32

# TMY-SVJBR

## Y-axis holder

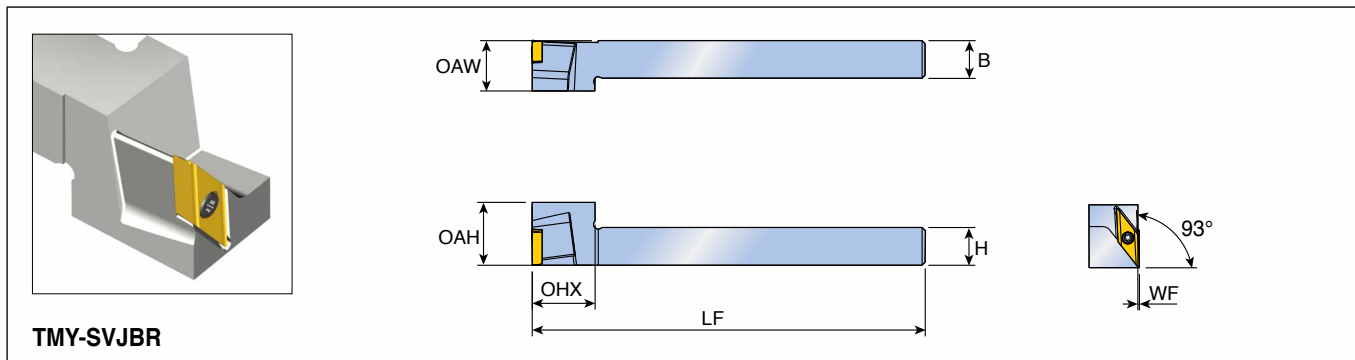

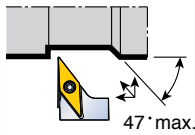

TMY-SVJBR

Approach angle	Designation	Dimension (mm)							Insert
		H	B	LF	OHX	OAH	OAW	WF	
93°	<b>TMY- SVJBR 1212 K11</b>	12	12	125	20	20	16	0	VB...T 1103...
	<b>SVJBR 1616 K11</b>	16	16	125	20	20	16	0	



## Spare parts

Designation	Screw	Wrench			
					
<b>TMY-SVJBR</b>	SO 25065I	T 7(T-7/5)			

# TMY-SVJBR-TB

## Y-axis holder (*T-BÜRST*) HIGH PRESSURE

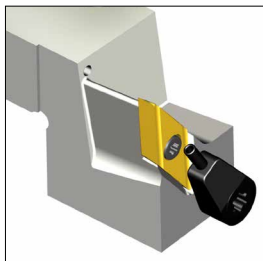

TMY-SVJBR-TB

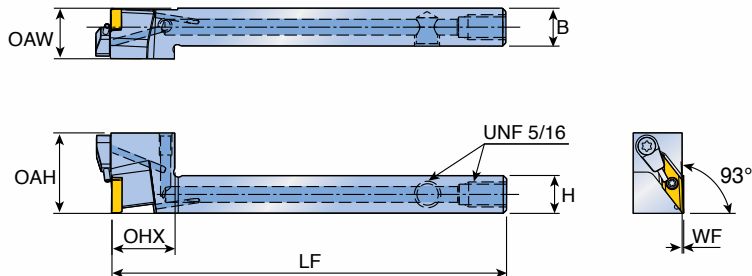

Approach angle	Designation	Dimension (mm)							Insert
		H	B	LF	OHX	OAH	OAW	WF	
93°	<b>TMY-SVJBR 1212 K11-TB</b>	12	12	125	20	25.5	16	0	VB...T 1103...
	<b>SVJBR 1616 K11-TB</b>	16	16	125	20	25.5	16	0	

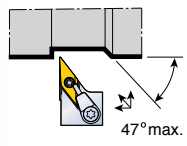

### Spare parts

Designation	Screw	Oil-supply unit	Plug	Wrench	
<b>TMY-SVJBR-TB</b>	SO 25065I	S-CU-TB	PLG 5/16 UNF	T 7(T-7/5)	L-W 5/32

# TMZ-SDJCR

## Shift holder

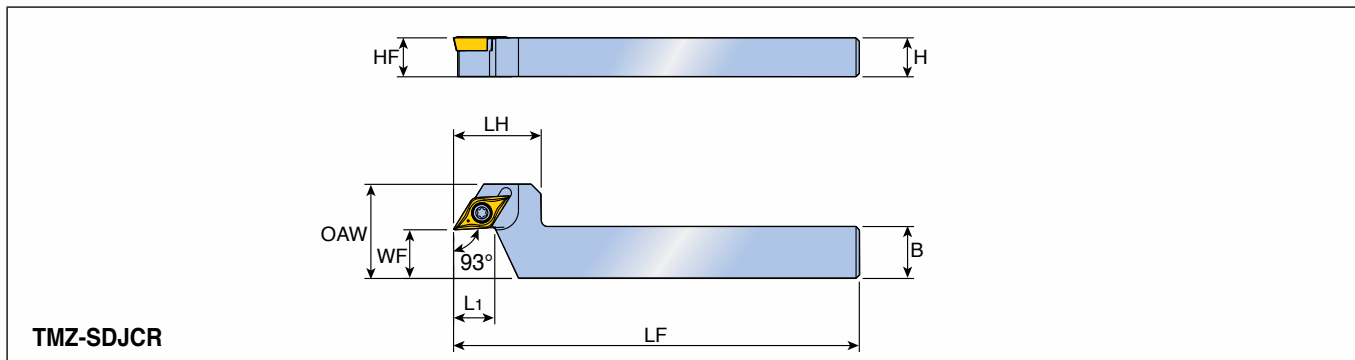

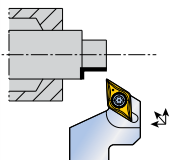

TMZ-SDJCR

Approach angle	Designation	Dimension (mm)								Insert
		H	HF	B	LF	L1	OAW	LH	WF	
93°	<b>TMZ- SDJCR 1216 K11-F15</b>	12	12	16	125	12.5	29	27	15	DC...T 11T3...
	<b>SDJCR 1620 K11-F15</b>	16	16	20	125	16.3	29	30	15	



## Spare parts

Designation	Screw	Wrench				
						
<b>TMZ-SDJCR</b>	SO 35080I	T 15				

# TMZ-SVLBR

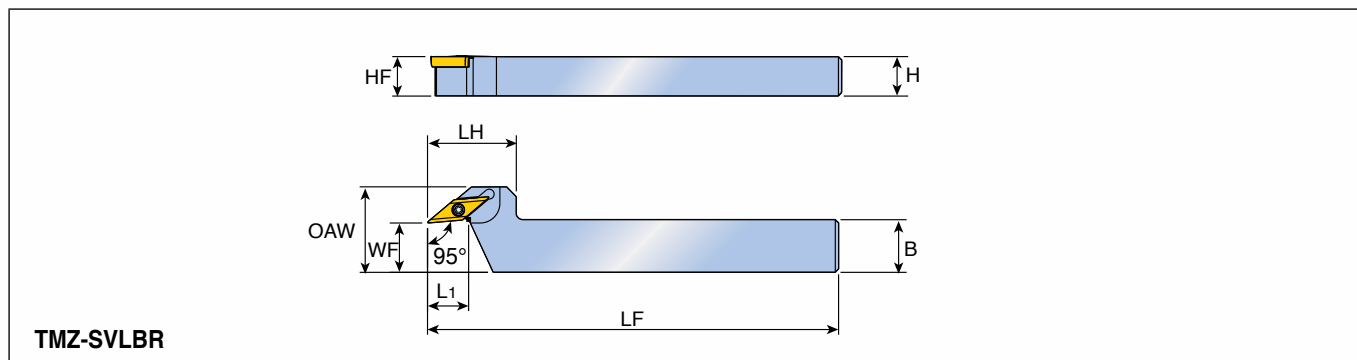

## Shift holder



TMZ-SVLBR

Approach angle	Designation	Dimension (mm)								Insert
		H	HF	B	LF	L1	OAW	LH	WF	
95°	<b>TMZ-SVLBR 1216 K11-F15</b>	12	12	16	125	12.3	26	27	15	VB...T 1103...
	<b>SVLBR 1620 K11-F15</b>	16	16	20	125	16.2	26	30	15	

## Spare parts

Designation	Screw	Wrench				
						
<b>TMZ-SVLBR</b>	SO 25065I	T 7(T-7/5)				