

NPN

New Product News



MAXIRUSH

INDEXABLE SOLID HEADS

Head Changeable Type Solid End Mill

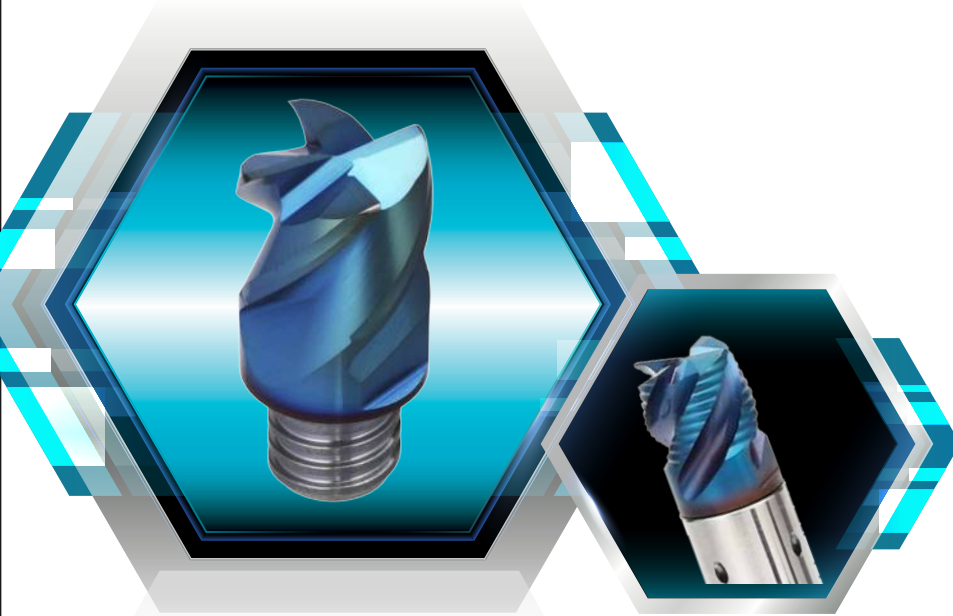

KEY POINT

TaeguTec has released a convenient head changeable type solid carbide end mill.

The innovative head changeable type solid carbide end mill, launched under the brand name **MAXI-RUSH**, replaces most of the existing conventional solid end mills machining range. The line is a new high productivity tooling solution offering outstanding advantages.

Superior performance is the result along with quick and easy indexable heads which reduce set up time and improve customer productivity. The **MAXI-RUSH** line is offered in many head types covering all applications; they also come in steel, carbide and tungsten shank holders in various lengths that can be combined to provide the widest flexibility in tooling solutions.

For further technical questions, please contact TaeguTec's product manager.

Features

- Rigid and precise double contact fastening system

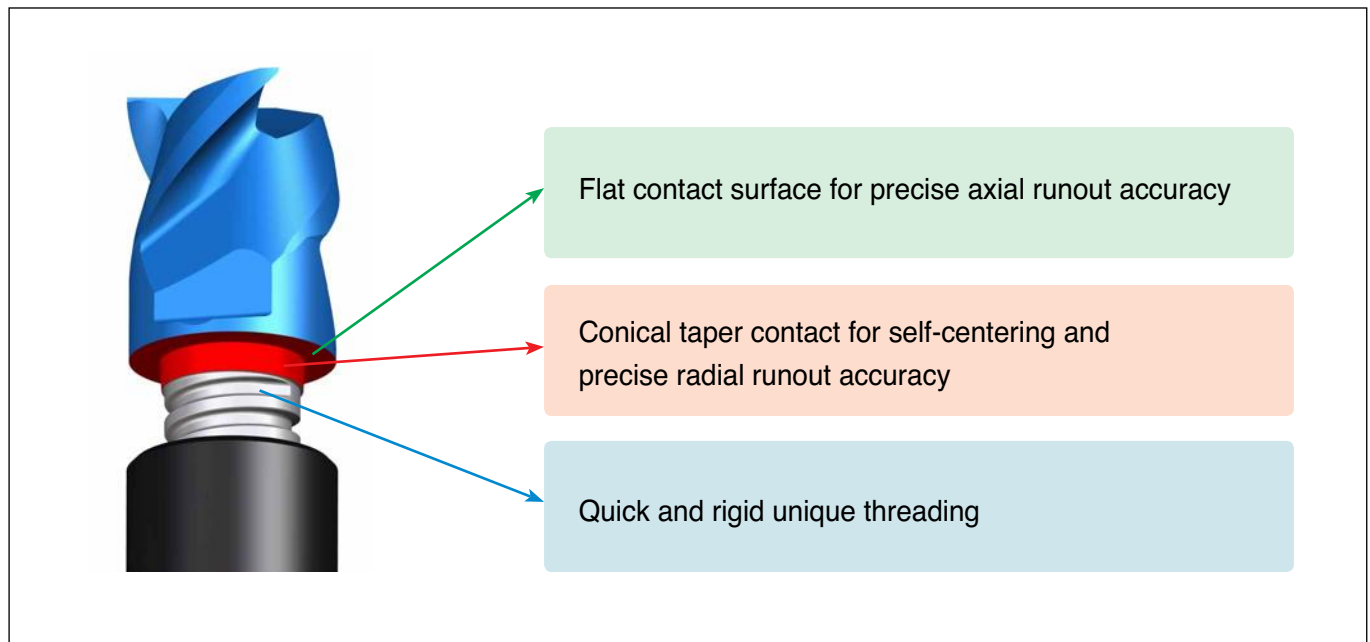

- Tooling downtime minimized by replacing the heads quickly

Collet chuck + MAXI-RUSH



Easy head replacement
with spindle engaged

Replacement
time is
dramatically
reduced

Collet chuck + end mill

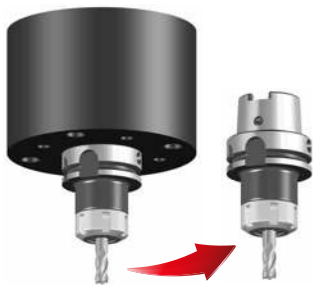

Separate the arbor
from the spindle

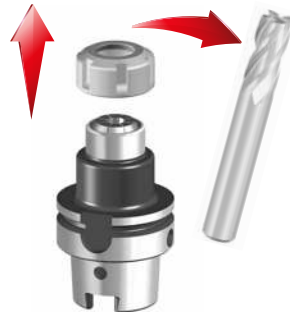

Secure the arbor to the tool post
and
remove the nut and the end mill



Set the height, if
necessary, after
tightening the end mill



Re-mount the arbor
to the spindle

- Available in a wide variety of indexable head types and shank types

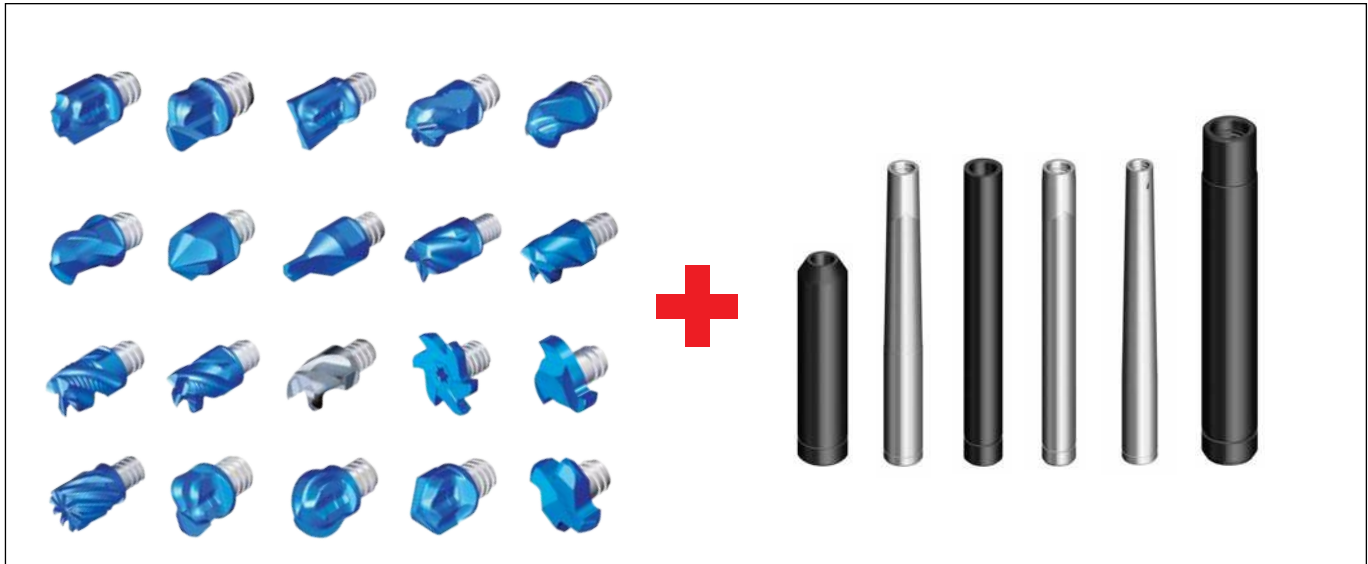

- Flat, ball, corner radius, chamfer, slot, etc
Available in various head types for all applications
- Available diameter range:
General: $\varnothing 6$ - $\varnothing 25$, Slot: $\varnothing 13.5$ - $\varnothing 27.7$

- With various shapes and lengths such as straight shanks with neck and taper neck in various materials, the optimal choice considering stiffness and interference
- Available in both steel, carbide and tungsten materials
- Internal through coolant capability

- Applied with the latest coating grade for dedicated MAXI-RUSH (TT5523, TT5543)

- Optimal combination of wear resistance and chipping resistance makes it suitable for various materials and applications
- Distinctive shiny blue color appearance

TT5523

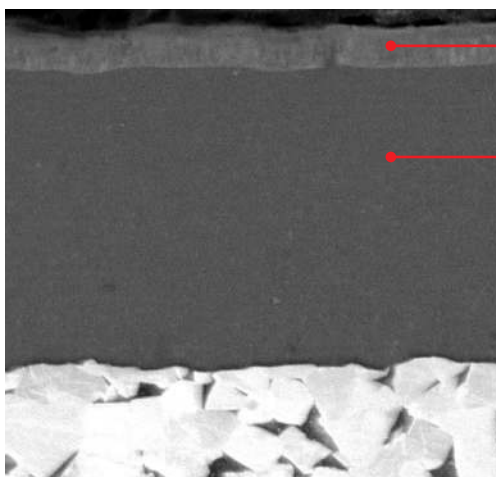

Unique blue color layer

Nano-crystalline structured AlTiN layer

- Excellent abrasion resistant sub-micron substrate
- Anti-abrasion and oxidation resistant PVD AlTiN coating layer
- High-speed milling of steel and cast iron, stainless steel and heat resistant super alloys
- Applied to all MAXI-RUSH items except the T-slot type

TT5543

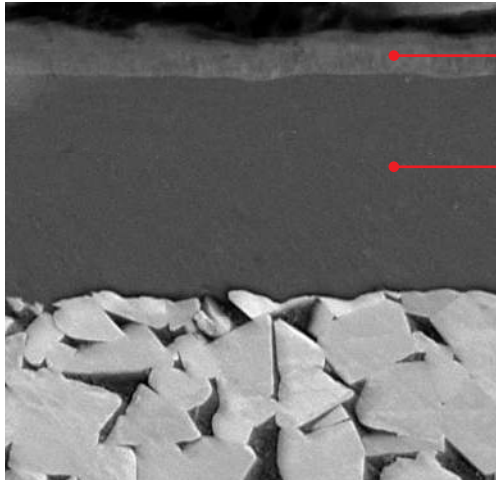

Unique blue color layer

Nano-crystalline
structured AlTiN layer

- Tough carbide grade with an advanced PVD AlTiN coating layer
- Suitable for T-Slot interrupted and rough machining of various materials
- Applied to T-slot items only



MXEE(D)-04

4 flute, for general purpose

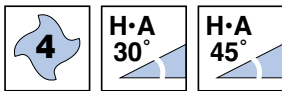
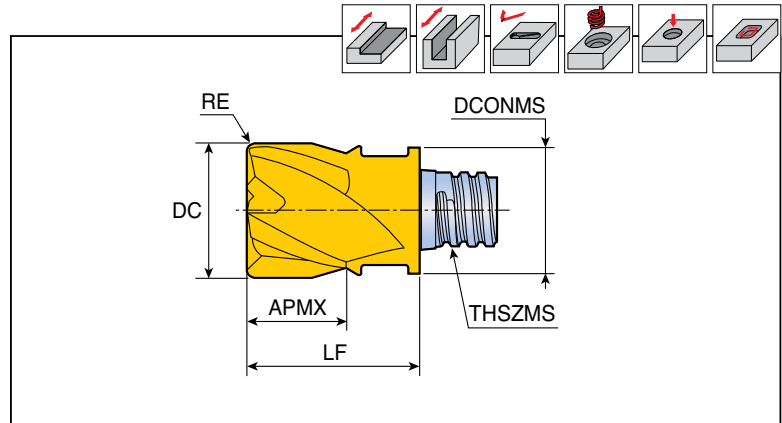

Designation	Feed (mm/tooth)	Dimension (mm)							Grade
		DC	RE	FHA	APMX	THSZMS	DCONMS	LF	
MXEE 060L05R00-04S05	0.025-0.060	6	-	45	5	S05	8	10	●
MXEE 080L05R00-04S05	0.030-0.080	8	-	45	5	S05	7.7	10	●
MXED 080L05R05-04S05	0.030-0.080	8	0.5	30	5	S05	7.7	10	●
MXED 080L05R10-04S05	0.030-0.080	8	1.0	30	5	S05	7.7	10	●
MXED 080L05R15-04S05	0.030-0.080	8	1.5	30	5	S05	7.7	10	●
MXEE 100L07R00-04S06	0.035-0.090	10	-	45	7	S06	9.7	13	●
MXED 100L07R05-04S06	0.035-0.090	10	0.5	30	7	S06	9.7	13	●
MXEE 100L07R05-04S06	0.035-0.090	10	0.5	45	7	S06	9.7	13	●
MXED 100L07R10-04S06	0.035-0.090	10	1.0	30	7	S06	9.7	13	●
MXEE 100L07R10-04S06	0.035-0.090	10	1.0	45	7	S06	9.7	13	●
MXEE 120L09R00-04S08	0.035-0.110	12	-	45	9	S08	11.7	16.5	●
MXED 120L09R05-04S08	0.035-0.110	12	0.5	30	9	S08	11.7	16.5	●
MXEE 120L09R05-04S08	0.035-0.110	12	0.5	45	9	S08	11.7	16.5	●
MXED 120L09R10-04S08	0.035-0.110	12	1.0	30	9	S08	11.7	16.5	●
MXEE 120L09R10-04S08	0.035-0.110	12	1.0	45	9	S08	11.7	16.5	●
MXEE 160L12R00-04S10	0.040-0.130	16	-	45	12	S10	15.3	20.5	●
MXED 160L12R05-04S10	0.040-0.130	16	0.5	30	12	S10	15.3	20.5	●
MXEE 160L12R05-04S10	0.040-0.130	16	0.5	45	12	S10	15.3	20.5	●
MXED 160L12R10-04S10	0.040-0.130	16	1.0	30	12	S10	15.3	20.5	●
MXEE 160L12R40-04S10	0.040-0.130	16	4.0	45	12	S10	15.3	20.5	●
MXEE 200L15R00-04S12	0.050-0.150	20	-	45	15	S12	18.3	25.5	●
MXED 200L15R05-04S12	0.050-0.150	20	0.5	30	15	S12	18.3	25.5	●
MXED 200L15R10-04S12	0.050-0.150	20	1.0	30	15	S12	18.3	25.5	●
MXED 200L15R20-04S12	0.050-0.150	20	2.0	30	15	S12	18.3	25.5	●
MXED 200L15R30-04S12	0.050-0.150	20	3.0	30	15	S12	18.3	25.5	●

- Wrench should be ordered separately
- FHA: Flute helix angle

●: Standard items

MXEE-I04



4 flute, irregular-pitch flutes (vibration free)

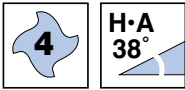
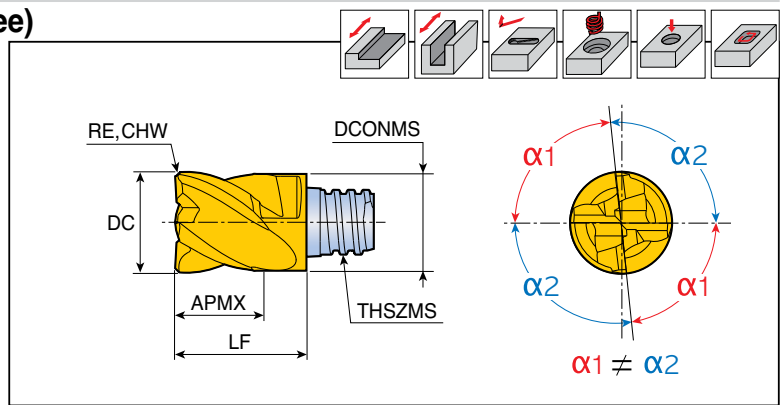

Designation	Feed (mm/tooth)	Dimension (mm)							Grade
		DC	RE	CHW	APMX	THSZMS	DCONMS	LF	
MXEE 080L05C30I04S05	0.030-0.080	8	-	0.3	5	S05	7.7	10	●
100L07C40I04S06	0.035-0.090	10	-	0.4	7	S06	9.7	13	●
120L09C50I04S08	0.035-0.110	12	-	0.5	9	S08	11.7	16.5	●
160L12C60I04S10	0.040-0.130	16	-	0.6	12	S10	15.3	20.5	●
200L15C60I04S12	0.050-0.150	20	-	0.6	15	S12	18.3	25.5	●
250L22R30I04S15	0.060-0.170	25	3.0	-	22	S15	23.9	37	●

● Wrench should be ordered separately

●: Standard items

MXEE-R



4-6 flute, for roughing

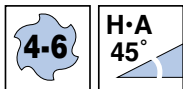
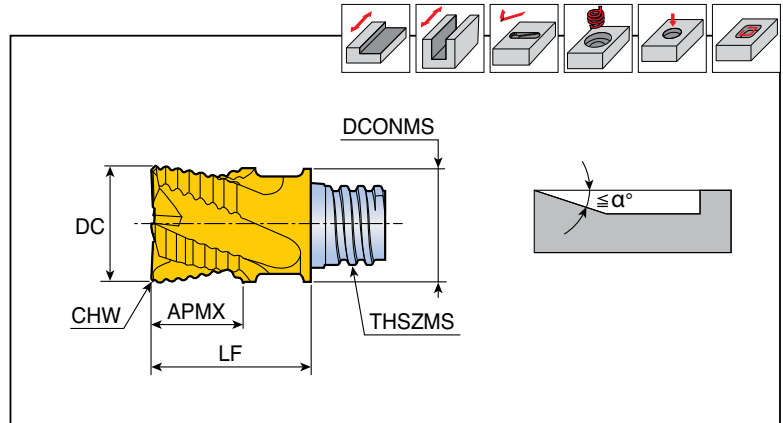

Designation	Feed (mm/tooth)	Dimension (mm)								Grade
		DC	NOF	APMX	CHW	THSZMS	DCONMS	LF	α°	
MXEE 080L05C25R04S05	0.030-0.080	8	4	5	0.25	S05	7.7	10	90	●
100L07C30R04S06	0.035-0.090	10	4	7	0.30	S06	9.7	13	90	●
120L09C35R04S08	0.035-0.110	12	4	9	0.35	S08	11.7	16.5	90	●
160L12C40R05S10	0.040-0.130	16	5	12	0.40	S10	15.3	20.5	7	●
200L15C40R06S12	0.050-0.150	20	6	15	0.40	S12	18.3	25.5	3	●
250L22C50R06S15	0.060-0.170	25	6	22	0.50	S15	23.9	37	3	●

- Wrench should be ordered separately
- NOF: Number of flutes

●: Standard items

MXEE-C04



4 flute, combined edges for finishing & roughing

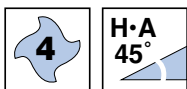
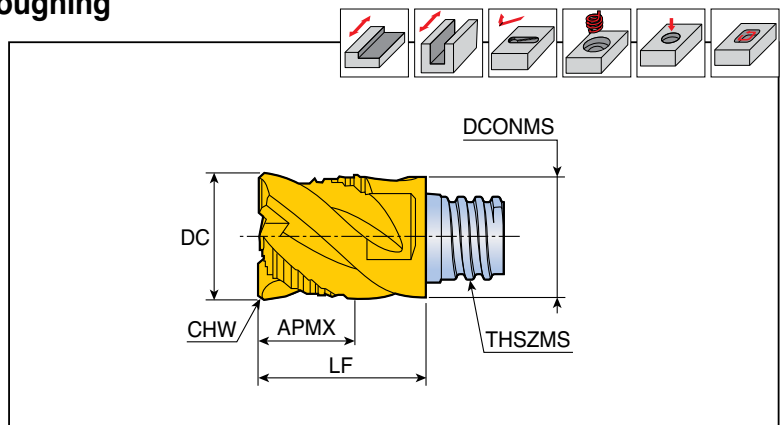

Designation	Feed (mm/tooth)	Dimension (mm)						Grade
		DC	APMX	CHW	THSZMS	DCONMS	LF	
MXEE 080L05C30C04S05	0.030-0.080	8	5	0.3	S05	7.7	10	●
100L07C30C04S06	0.035-0.090	10	7	0.3	S06	9.7	13	●
120L09C40C04S08	0.035-0.110	12	9	0.4	S08	11.7	16.5	●
160L12C60C04S10	0.040-0.130	16	12	0.6	S10	15.3	20.5	●
200L15C60C04S12	0.050-0.150	20	15	0.6	S12	18.3	25.5	●
250L22C60C04S15	0.060-0.170	25	22	0.6	S15	23.9	37	●

- Wrench should be ordered separately

●: Standard items

MXEE(D)-06



6 flute, for difficult-to-cut material machining without central edge

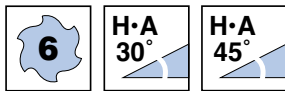
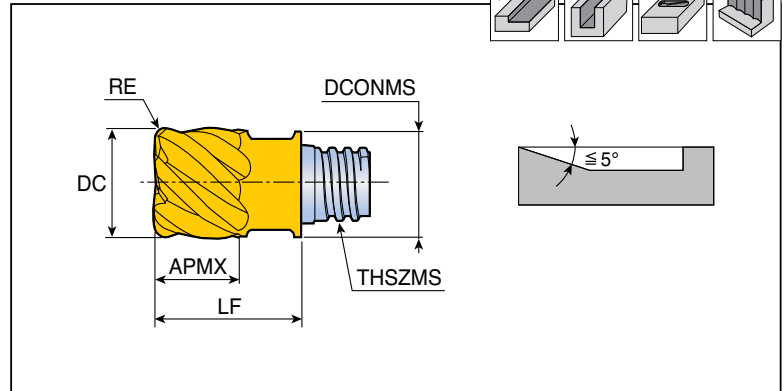
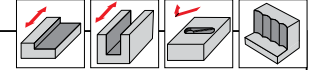

Designation	Feed (mm/tooth)	Dimension (mm)							Grade
		DC	RE	FHA	APMX	THSZMS	DCONMS	LF	TT5523
MXEE 08L05R05-06S05	0.030-0.080	8	0.5	45	5	S05	7.7	10	●
MXEE 08L05R10-06S05	0.030-0.080	8	1.0	45	5	S05	7.7	10	●
MXED 100L07R05-06S06	0.035-0.090	10	0.5	30	7	S06	9.7	13	●
MXED 100L07R10-06S06	0.035-0.090	10	1.0	30	7	S06	9.7	13	●
MXEE 100L07R05-06S06	0.035-0.090	10	0.5	45	7	S06	9.7	13	●
MXEE 120L09R10-06S08	0.035-0.110	12	1.0	45	9	S08	11.7	16.5	●

- Wrench should be ordered separately
- FHA: Flute Helix Angle
- Standard items

MXED-08/10



8, 10 flute, for difficult-to-cut material machining without central edge

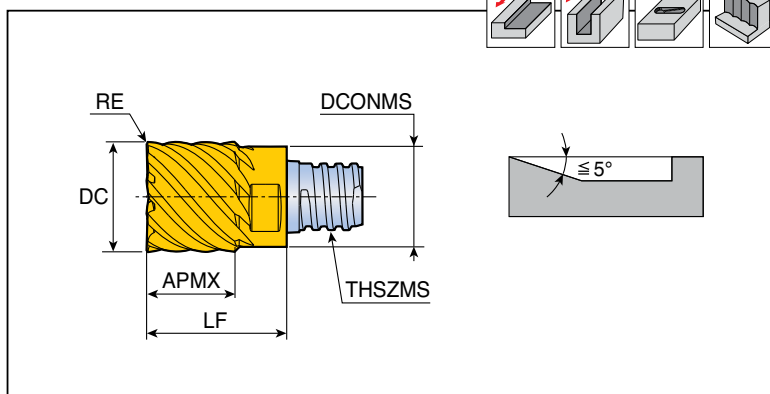
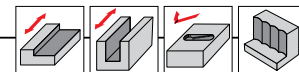

Designation	Feed (mm/tooth)	Dimension (mm)							Grade
		DC	NOF	RE	APMX	THSZMS	DCONMS	LF	
MXED 160L12R05-08S10	0.040-0.130	16	8	0.5	12	S10	15.3	20.5	●
160L12R10-08S10	0.040-0.130	16	8	1.0	12	S10	15.3	20.5	●

● Wrench should be ordered separately
 ● NOF: Number of flutes
 ● Standard items

MXFX-02

2 flute, for high feed milling

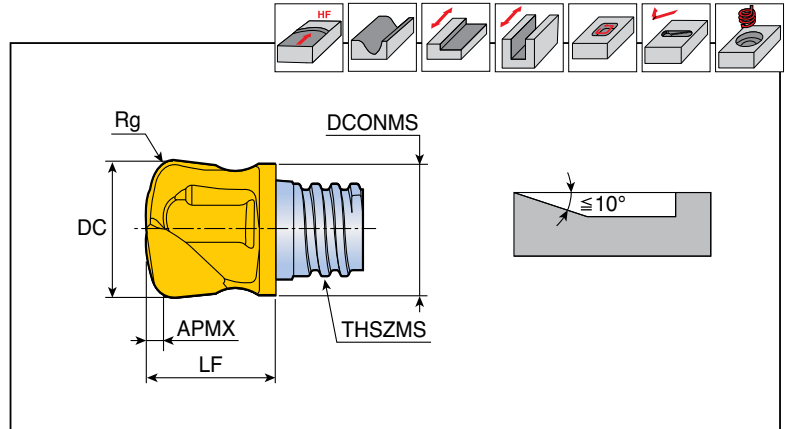

Designation	Feed (mm/tooth)	Dimension (mm)						Grade
		DC	Rg	APMX	THSZMS	DCONMS	LF	
MXFX 100L0.6R20-02S06	0.035-0.090	10	2.0	0.6	S06	9.6	12.5	●
120L01R25-02S08	0.035-0.110	12	2.5	1.0	S08	11.5	11.1	●
160L1.1R30-02S10	0.040-0.130	16	3.0	1.1	S10	15.2	20	●

- Wrench should be ordered separately
- Rg: Radius for programmers

●: Standard items

MXBD-BG-02

2 flute, for high precision machining

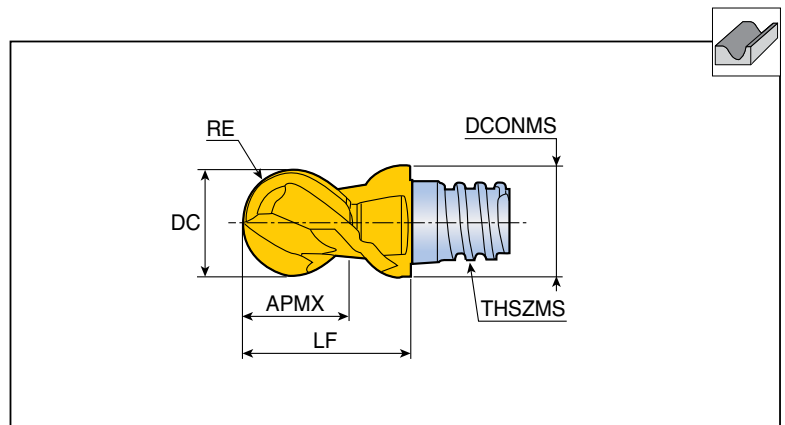

Designation	Feed (mm/tooth)	Dimension (mm)						Grade
		DC	RE	APMX	THSZMS	DCONMS	LF	
MXBD 080L05-BG-02S05	0.030-0.080	8	3.982 ⁽¹⁾	5	S05	7.7	10	●
100L07-BG-02S06	0.035-0.090	10	4.982 ⁽¹⁾	7	S06	9.7	13	●
120L09-BG-02S08	0.035-0.110	12	5.978 ⁽²⁾	9	S08	11.7	16.5	●
160L09-BG-02S10	0.040-0.130	16	7.978 ⁽²⁾	9	S10	15.3	20.5	●

- Wrench should be ordered separately
- RE Tolerance: ⁽¹⁾± 0.01, ⁽²⁾± 0.012

●: Standard items

MXBD(E)-BG-04

4 flute, for high precision machining

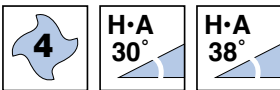
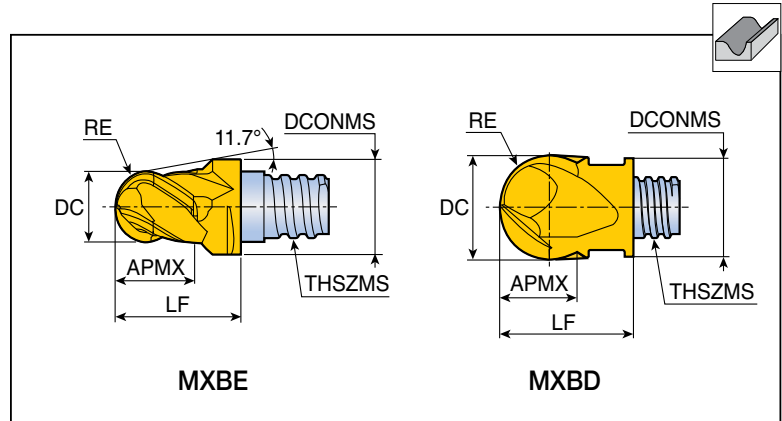

Designation	Feed (mm/tooth)	Dimension (mm)							Grade
		DC	RE	FHA	APMX	THSZMS	DCONMS	LF	
MXBE 060L05-BG-04S05	0.025-0.060	6	2.987 ⁽¹⁾	38	5.5	S05	8.0	10	●
MXBD 080L05-BG-04S05	0.030-0.080	8	3.982 ⁽¹⁾	30	5	S05	7.7	10	●
100L07-BG-04S06	0.035-0.090	10	4.982 ⁽¹⁾	30	7	S06	9.7	13	●
120L09-BG-04S08	0.035-0.110	12	5.978 ⁽²⁾	30	9	S08	11.7	16.5	●
160L12-BG-04S10	0.040-0.130	16	7.978 ⁽²⁾	30	12	S10	15.3	20.5	●
200L15-BG-04S12	0.050-0.150	20	9.972 ⁽²⁾	30	15	S12	18.3	25.5	●
250L22-BG-04S15	0.060-0.170	25	12.470 ⁽³⁾	30	22	S15	23.9	37	●

- Wrench should be ordered separately
- RE Tolerance: ⁽¹⁾± 0.01, ⁽²⁾± 0.012, ⁽³⁾± 0.02
- FHA: Flute helix angle

●: Standard items

MXCP-02



2 flute, for spot drilling, chamfering and countersinking

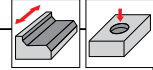
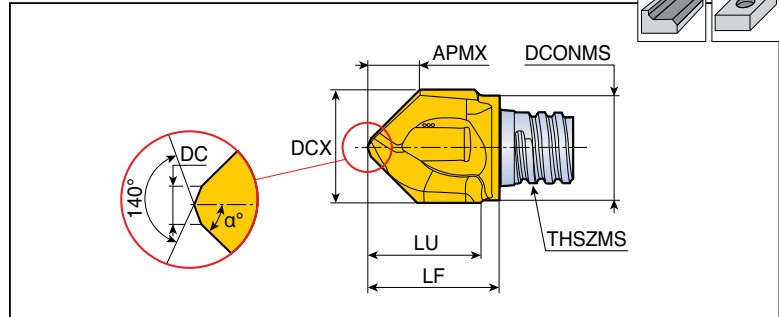

Designation	Feed (mm/tooth)	Dimension (mm)								Grade
		DCX	DC	APMX	THSZMS	DCONMS	LU	LF	α°	
MXCP 100L09A30-02S06	0.035-0.090	10	1.5	7.5	S06	9.5	8.5	11.75	30	●
120L12A30-02S08	0.035-0.110	12	1.5	9.2	S08	11.5	11	15.4	30	●
160L15A30-02S10	0.040-0.130	16	2.5	12	S10	15.2	16	20.2	30	●
080L07A45-02S05	0.030-0.080	8	1.0	3.7	S05	7.6	7.5	9.75	45	●
083L07A45-02S05	0.030-0.080	8.3	1.0	3.8	S05	7.6	7.5	10	45	●
100L09A45-02S06	0.035-0.090	10	1.5	4.4	S06	9.5	9.5	11.75	45	●
104L09A45-02S06	0.035-0.090	10.4	1.5	4.6	S06	9.5	9.5	11.75	45	●
120L12A45-02S08	0.035-0.110	12	1.5	5.4	S08	11.5	11.5	15.4	45	●
124L12A45-02S08	0.035-0.110	12.4	1.5	5.6	S08	11.5	11.5	15.4	45	●
160L15A45-02S10	0.040-0.130	16	1.5	7.1	S10	15.2	15	18.8	45	●
165L15A45-02S10	0.040-0.130	16.5	1.5	7.1	S10	15.2	15	18.8	45	●
100L09A60-02S06	0.035-0.090	10	1.5	2.7	S06	9.5	9.5	12.7	60	●
120L12A60-02S08	0.035-0.110	12	1.5	3.3	S08	11.5	11.5	15.2	60	●
160L15A60-02S10	0.040-0.130	16	1.5	4.4	S10	15.2	16	19.9	60	●

● Wrench should be ordered separately

● Standard items



MXDP-02

2 flute, for center drilling

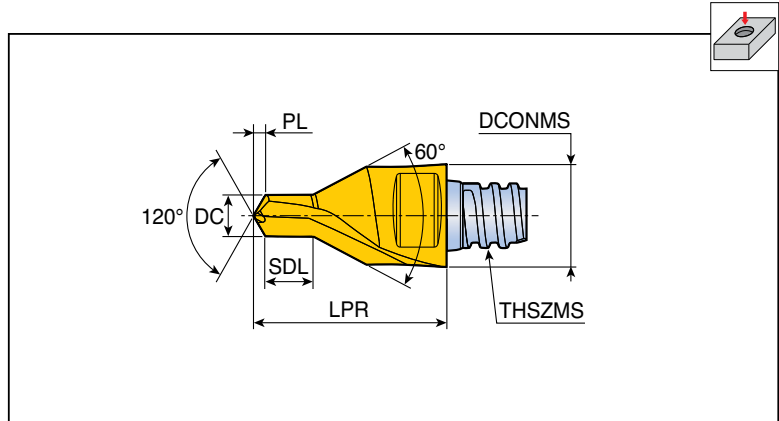

Designation	Feed (mm/tooth)	Dimension (mm)						Grade
		DC	PL	SDL	THSZMS	DCONMS	LPR	
MXDP 328L04A30-02S05	0.04-0.08	3.28	0.85	3.75	S05	8	15	●
412L05A30-02S06	0.05-0.10	4.12	1.07	4.83	S06	10	19	●
513L07A30-02S08	0.05-0.12	5.13	1.32	5.88	S08	12	23	●
646L08A30-02S10	0.06-0.15	6.46	1.65	7.25	S10	16	28	●

- Wrench should be ordered separately
- SDL : Step diameter length

●: Standard items

MXCA-04/06



4, 6 flute, chamfering and countersinking (without center edge)

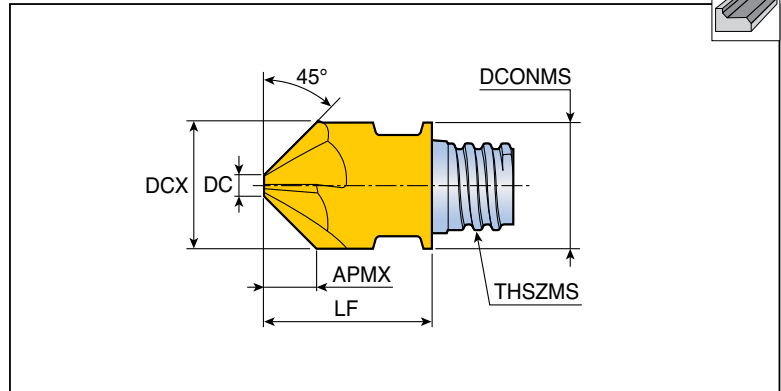

Designation	Feed (mm/tooth)	Dimension (mm)							Grade
		DCX	DC	NOF	APMX	THSZMS	DCONMS	LF	
MXCA 100L04A45-04S06	0.035-0.090	10	1.95	4	4.0	S06	10	13	●
120L05A45-04S08	0.035-0.110	12	1.95	4	5.0	S08	12	16.5	●
127L05A45-04S08	0.035-0.110	12.7	1.98	4	5.3	S08	12.7	16.5	●
160L06A45-06S10	0.040-0.130	16	3.0	6	6.5	S10	16	20.3	●
200L07A45-06S12	0.050-0.150	20	5.0	6	7.5	S12	20	25.5	●

- Wrench should be ordered separately
- NOF: Number of flutes

●: Standard items

MXCW-02



2 flute, for double chamfering

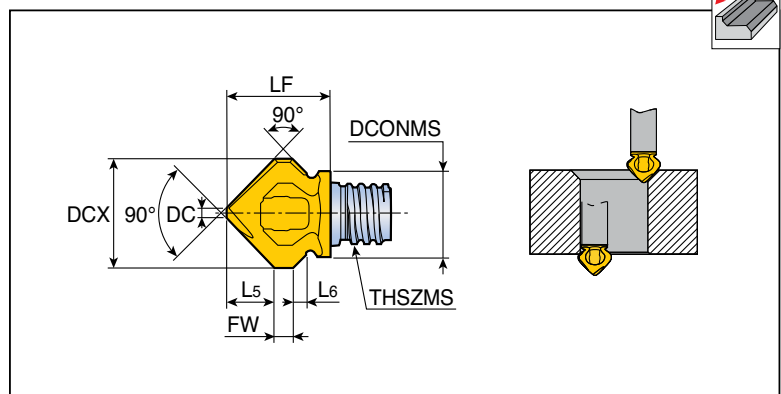

Designation	Feed (mm/tooth)	Dimension (mm)							Grade	
		DCX	DC	L5	L6	FW	THSZMS	DCONMS		LF
MXCW 118L05A45-02S06	0.035-0.110	11.8	1.2	5	1.2	2	S06	9.3	11.2	●

- Wrench should be ordered separately

●: Standard items

TST-4/6

4, 6 flute, for slotting

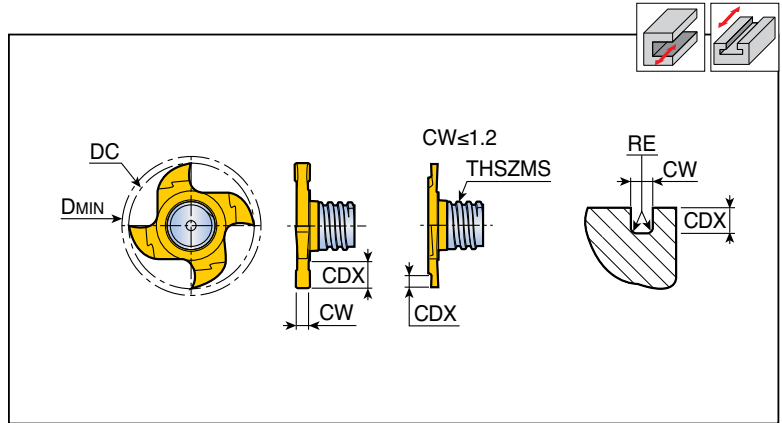

Designation	Feed (mm/tooth)	Dimension (mm)							Torx	Grade
		DC	NOF	CW	CDX	RE	THSZMS	D _{MIN}		
TST 217W1.95R020-4S08	0.025-0.120	21.7	4	1.95 ⁽¹⁾	4.5	0.2	S08	22.0	-	●
217W2.0R020-4S08	0.025-0.120	21.7	4	2.0	4.5	0.2	S08	22.0	-	●
217W2.50R020-4S08	0.025-0.120	21.7	4	2.5	4.5	0.2	S08	22.0	-	●
217W2.75R020-4S08	0.025-0.130	21.7	4	2.75 ⁽¹⁾	4.5	0.2	S08	22.0	-	●
217W3.0R020-4S08	0.025-0.130	21.7	4	3.0	4.5	0.2	S08	22.0	-	●
217W4.0R020-4S08	0.025-0.150	21.7	4	4.0	4.5	0.2	S08	22.0	-	●
217W4.25R020-4S08	0.025-0.150	21.7	4	4.25 ⁽¹⁾	4.5	0.2	S08	22.0	-	●
277W2.50R020-6S10	0.025-0.120	27.7	6	2.5	6	0.2	S10	28.0	T40	●
277W5.25R020-6S10	0.025-0.170	27.7	6	5.25	6	0.2	S10	28.0	T40	●
277W10R020-6S10	0.025-0.170	27.7	6	10.0	6	0.2	S10	28.0	T40	●

- Wrench should be ordered separately
- NOF: Number of flutes
- ⁽¹⁾ CW for circle clips according to DIN 471/472
- Standard items

TTB-06

6 flute, for slotting

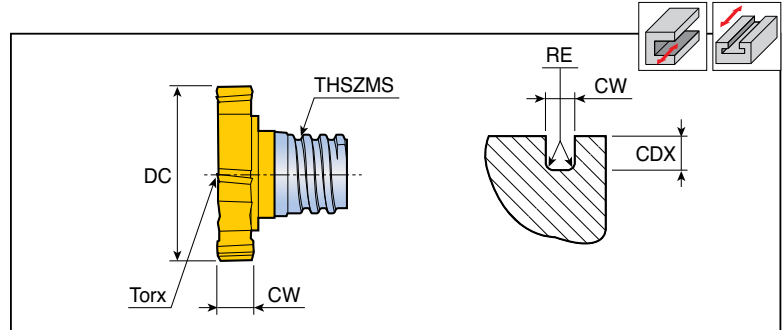

Designation	Feed (mm/tooth)	Dimension (mm)					Torx	Grade TT5543
		DC	CW	CDX	RE	THSZMS		
TTB 135W3.0R04-06S05	0.025-0.130	13.5	3	2.65	0.4	S05	T20	●
135W4.0R04-06S05	0.025-0.150	13.5	4	2.65	0.4	S05	T20	●
160W2.0R04-06S06	0.025-0.120	16	2	2.9	0.4	S06	T20	●
160W3.0R04-06S06	0.025-0.130	16	3	2.9	0.4	S06	T25	●
160W4.0R04-06S06	0.025-0.150	16	4	2.9	0.4	S06	T25	●
165W2.0R04-06S06	0.025-0.120	16.5	2	3.15	0.4	S06	T20	●
165W3.0R04-06S06	0.025-0.130	16.5	3	3.15	0.4	S06	T25	●
165W4.0R04-06S06	0.025-0.150	16.5	4	3.15	0.4	S06	T25	●
195W4.0R04-06S08	0.025-0.150	19.5	4	3.45	0.4	S08	T30	●
195W5.0R04-06S08	0.025-0.150	19.5	5	3.45	0.4	S08	T30	●
195W6.0R04-06S08	0.025-0.170	19.5	6	3.45	0.4	S08	T30	●
225W5.0R04-06S08	0.025-0.150	22.5	5	4.95	0.4	S08	T40	●
225W6.0R04-06S08	0.025-0.170	22.5	6	4.95	0.4	S08	T40	●
225W8.0R04-06S08	0.025-0.170	22.5	8	4.95	0.4	S08	T40	●
250W6.0R04-06S08	0.025-0.170	25	6	5.9	0.4	S08	T50	●
250W8.0R04-06S08	0.025-0.170	25	8	5.9	0.4	S08	T50	●
250W5.0R04-06S10	0.025-0.150	25	5	4.3	0.4	S10	T50	●
250W6.0R04-06S10	0.025-0.170	25	6	4.3	0.4	S10	T50	●
250W8.0R04-06S10	0.025-0.170	25	8	4.3	0.4	S10	T50	●

● Wrench should be ordered separately

●: Standard items

MXSSD

Straight shank and neck

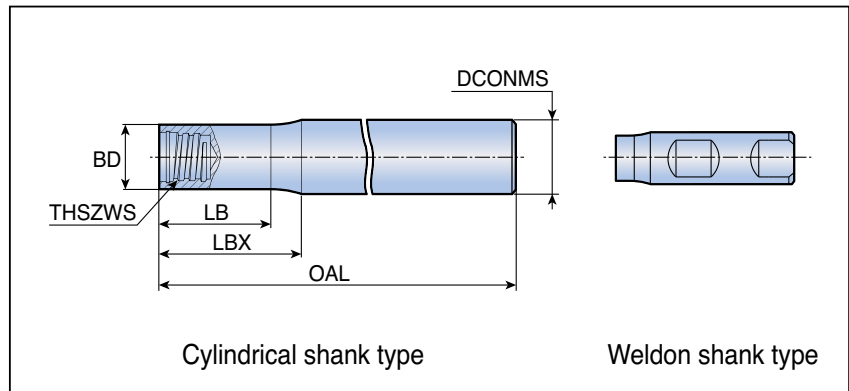

Designation	Dimension (mm)						Shank type	Shank material
	THSZWS	DCONMS	BD	OAL	LB	LBX		
MXSSD 08L060S05-S	S05	8	7.6	60	12.8	15	Cylindrical	Steel
08L070S05-C	S05	8	7.6	70	19	20	Cylindrical	Carbide
08L090S05-C	S05	8	7.6	90	39	40	Cylindrical	Carbide
08L110S05-C	S05	8	7.6	110	59	60	Cylindrical	Carbide
10L070S06-C	S06	10	9.6	70	18.5	20	Cylindrical	Carbide
10L075S06-S	S06	10	9.6	75	17.7	20	Cylindrical	Steel
10L090S06-C	S06	10	9.6	90	38.5	40	Cylindrical	Carbide
10L110S06-C	S06	10	9.6	110	58.5	60	Cylindrical	Carbide
10L150S06-C	S06	10	9.6	150	98.5	100	Cylindrical	Carbide
12L055W05-S	S05	12	7.6	55	-	3.8	Weldon	Steel
12L070S08-C	S08	12	11.5	70	17	20	Cylindrical	Carbide
12L090S08-C	S08	12	11.5	90	37	40	Cylindrical	Carbide
12L090S08-S	S08	12	11.5	90	13.6	16	Cylindrical	Steel
12L110S08-C	S08	12	11.5	110	57	60	Cylindrical	Carbide
12L130S08-C	S08	12	11.5	130	77	80	Cylindrical	Carbide
16L065W06-S	S06	16	9.6	65	-	6	Weldon	Steel
16L065W08-S	S08	16	11.5	65	-	4	Weldon	Steel
16L090S10-C	S10	16	15.2	90	38	40	Cylindrical	Carbide
16L100S10-S	S10	16	15.2	100	18	20	Cylindrical	Steel
16L110S10-C	S10	16	15.2	110	58	60	Cylindrical	Carbide
16L130S10-C	S10	16	15.2	130	78	80	Cylindrical	Carbide
16L150S10-C	S10	16	15.2	150	98	100	Cylindrical	Carbide
20L070W10-S	S10	20	15.2	70	-	4	Weldon	Steel
20L090S12-C	S12	20	18.3	90	37	40	Cylindrical	Carbide
20L120S12-S	S12	20	18.3	120	20.5	25	Cylindrical	Steel
20L130S12-C	S12	20	18.3	130	77	80	Cylindrical	Carbide

• THSZWS: Connection thread size

MXSSD-W-A



Straight shank and neck with internal coolant hole

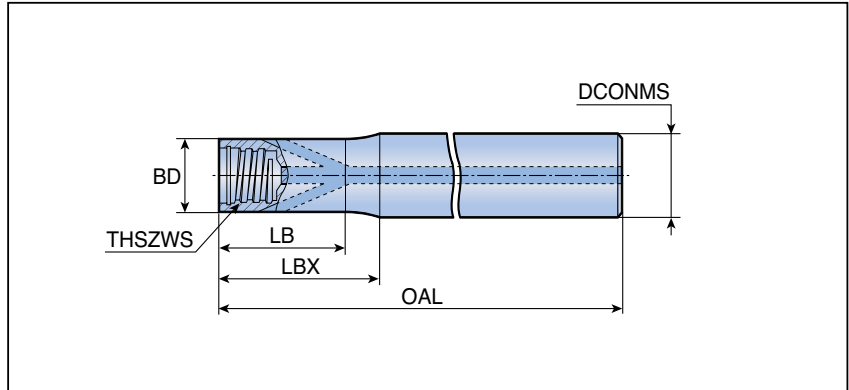

Designation	Dimension (mm)						Shank material
	THSZWS	DCONMS	BD	OAL	LB	LBX	
MXSSD 10L070S06-W-A	S06	10	9.6	70	19	20	Tungsten
10L090S06-W-A	S06	10	9.6	90	39	40	Tungsten
10L110S06-W-A	S06	10	9.6	110	59	60	Tungsten
12L070S08-W-A	S08	12	11.5	70	19	20	Tungsten
12L090S08-W-A	S08	12	11.5	90	39	40	Tungsten
12L110S08-W-A	S08	12	11.5	110	59	60	Tungsten
12L130S08-W-A	S08	12	11.5	130	79	80	Tungsten
16L070S10-W-A	S10	16	15.2	70	18.5	20	Tungsten
16L090S10-W-A	S10	16	15.2	90	36.5	40	Tungsten
16L110S10-W-A	S10	16	15.2	110	58.5	60	Tungsten
16L130S10-W-A	S10	16	15.2	130	78.5	80	Tungsten

• THSZWS: Connection thread size



MXTSD

Straight shank and taper neck

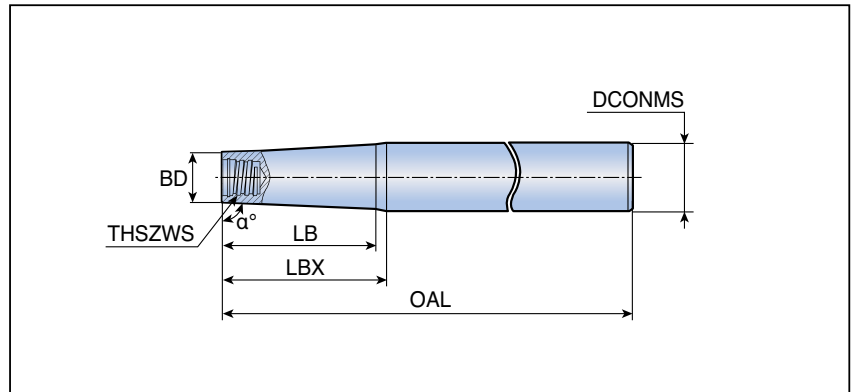

Designation	Dimension (mm)							Shank material
	α°	THSZWS	DCONMS	BD	OAL	LB	LBX	
MXTSD 12L080S05-S	85	S05	12	7.6	80	-	25	Steel
12L100S05-S	89	S05	12	7.6	100	31.0	35	Steel
12L110S05-C	89	S05	12	7.6	110	58.0	60	Carbide
12L130S05-C	89	S05	12	7.6	130	79.0	80	Carbide
16L125S06-S	85	S06	16	9.6	125	31.6	34	Steel
16L130S08-C	89	S08	16	11.5	130	78.8	80	Carbide
16L140S08-S	85	S08	16	11.5	140	19.3	22	Steel
16L150S05-C	89	S05	16	7.6	150	96.0	100	Carbide
16L150S06-C	89	S06	16	9.6	150	98.0	100	Carbide
16L150S08-C	89	S08	16	11.5	150	-	100	Carbide
16L160S06-S	89	S06	16	9.6	160	45.9	55	Steel
16L170S06-C	89	S06	16	9.6	170	119.0	120	Carbide
20L140S10-S	85	S10	20	15.2	140	-	27.5	Steel
20L170S08-C	89	S08	20	11.5	170	117.0	120	Carbide
20L170S08-S	89	S08	20	11.5	170	68.6	80	Steel
20L170S10-C	89	S10	20	15.2	170	-	120	Carbide
20L190S10-C	89	S10	20	15.2	190	-	140	Carbide
20L190S10-S	89	S10	20	15.2	190	73.0	80	Steel
20L210S10-C	89	S10	20	15.2	210	-	160	Carbide
25L160S12-S	85	S12	25	18.3	160	-	40	Steel
25L170S10-S	85	S10	25	15.2	170	-	56	Steel
25L180S12-C	89	S12	25	18.3	180	-	120	Carbide
25L210S12-S	89	S12	25	18.3	210	91.0	100	Steel
25L250S12-C	89	S12	25	18.3	250	-	140	Carbide
32L155S15-S	85	S15	32	23.9	155	40.0	45	Steel
32L190S12-S	85	S12	32	18.3	190	-	80	Steel

• THSZWS: Connection thread size

MXSC



Straight carbide shanks for TST type slotting head

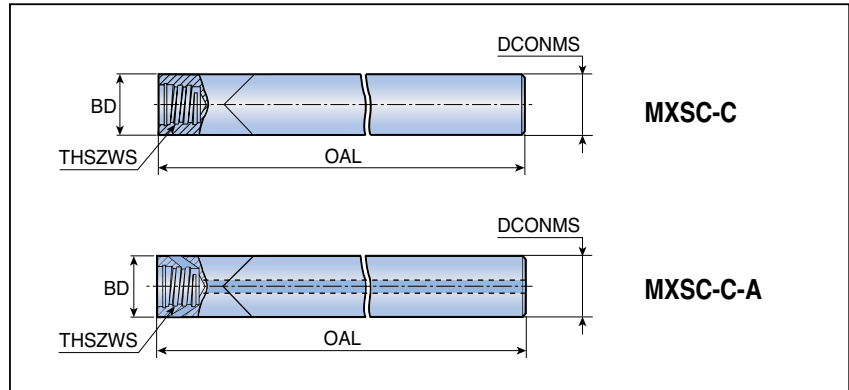

Designation	Dimension (mm)				Internal coolant	Shank material
	THSZWS	DCONMS	BD	OAL		
MXSC 100L100S06-C	S06	10	10	100	x	Carbide
120L100S08-C-A	S08	12	12	100	•	Carbide

- THSZWS: Connection thread size

Note:

- For MXSC type shank, it is recommended to use the TST slotting head only. If other heads are used on the MXSC shank, the depth of cut must be smaller than the max. ap in each head. The MXSC type shank does not have external clearance, so the shank may interfere with the work piece.

MXSTD



Straight shanks for TTB type slotting head

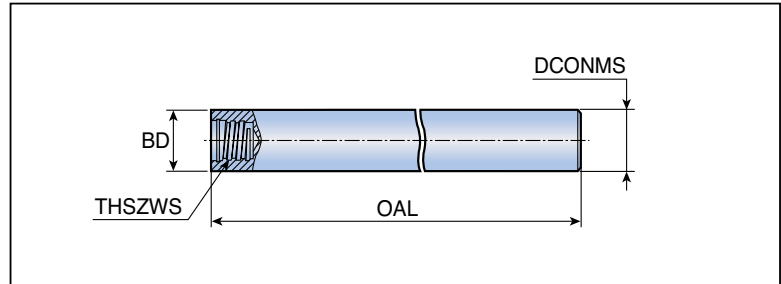

Designation	Dimension (mm)				Shank material
	THSZWS	DCONMS	BD	OAL	
MXSTD 08L070S05-S	S05	8	8	70	Steel
10L080S06-S	S06	10	10	80	Steel
12L090S08-S	S08	12	12	90	Steel
16L100S10-S	S10	16	16	100	Steel

- THSZWS: Connection thread size

Note:

- For MXSTD type shank, it is recommended to use the TTB slotting head only. If other heads are used on the MXSTD shank, the depth of cut must be smaller than the max. ap in each head. The MXSTD type shank does not have external clearance, so the shank may interfere with the work piece.

MXER



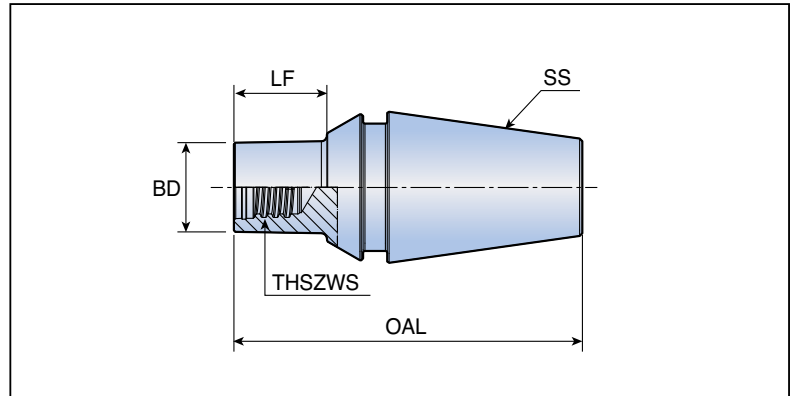

ER collet chucks conversion adaptor with MAXI-RUSH



Designation	Dimension (mm)					Shank material
	SS	THSZWS	BD	LF	OAL	
MXER 11CL006S05-S	ER11	S05	7.92	6	24.0	Steel
11CL020S05-S	ER11	S05	7.92	20	38.0	Steel
16CL012S05-S	ER16	S05	7.92	12	39.5	Steel
16CL020S05-S	ER16	S05	7.92	20	47.5	Steel
16CL010S06-S	ER16	S06	9.92	10	37.5	Steel
16CL020S06-S	ER16	S06	9.92	20	47.5	Steel
16CL006S08-S	ER16	S08	11.6	6	33.5	Steel
16CL020S08-S	ER16	S08	11.6	20	47.5	Steel

• THSZWS: Connection thread size

Wrench

Appearance	Designation	Connection thread size	Torque (N.m)	Head
	MX KEY-S05	S05	7	Square Ball Round Drilling Chamfering Counter boring
	MX KEY-S06	S06	10	
	MX KEY-S08	S08	15	
	MX KEY-S10	S10	28	
	MX KEY-S12	S12	28	
	MX KEY-S15	S15	40	
	MX SKEY-S06	S06	10	Slotting TST type
	MX SKEY-S08	S08	15	
	MX SKEY-T40L	S08	15	Slotting TST, TTB type
		S10	28	
	MX SKEY-T20	S05	7	
		S06	10	
	MX SKEY-T25	S06	10	
	MX SKEY-T30L	S08	15	
MX SKEY-T50L	S08	15		
		S10	28	

• Wrench should be ordered separately

Torque wrench

Appearance	Designation	Connection	Head designation	Torque (N.m)
Handle 	TORQUE WRENCH 5-50Nm 9X12			
Open wrench for cylindrical head 	MX WRENCH 6-05	S05	MXED, MXEE MXRD, MXBE MXDP, MXCA	7
	MX WRENCH 8-06	S06		10
	MX WRENCH 10-08	S08		15
	MX WRENCH 13-10	S10		28
	MX WRENCH 16-12	S12		28
	MX WRENCH 20-15	S15		40
Open wrench for 2 flutes head 	MX WRENCH 4E-05	S05	MXRB, MXFX MXBB MXCP, MXGC MXCW, MXCR	7
	MX WRENCH 5E-06	S06		10
	MX WRENCH 7E-08	S08		15
	MX WRENCH 8E-10	S10		28
	MX WRENCH 9E-12	S12		28
90° adapter for torx bit 	INSERT TOOL 9X12MM			
Torx bit socket 	BIT SOCKET T20 DRIVE	S05, S06	TTB TST277	7, 10
	BIT SOCKET T25 DRIVE	S06		10
	BIT SOCKET T30 DRIVE	S08		15
	BIT SOCKET T40 DRIVE	S08, S10		15, 28
	BIT SOCKET T50 DRIVE	S08, S10		15, 28

• Wrench should be ordered separately

Recommended Cutting Conditions

Fz for Square & Round heads

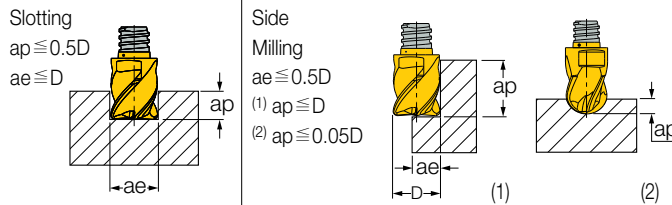

D (mm)	Fz (mm/t)	D (mm)	Fz (mm/t)
6	0.027-0.05	6	0.027-0.06
8	0.032-0.07	8	0.032-0.08
10	0.034-0.08	10	0.034-0.09
12	0.036 - 0.1	12	0.036-0.11
16	0.05 - 0.12	16	0.05 - 0.13
20	0.052-0.14	20	0.052-0.15
25	0.062-0.15	25	0.062-0.17

Fz for Slotting heads

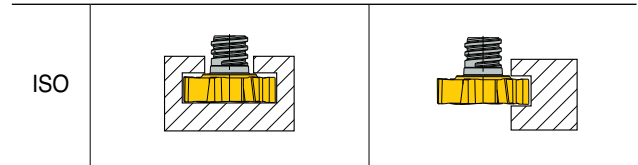

ISO	Fz (mm/t)	Fz (mm/t)
P	0.025-0.12	0.035-0.15
M	0.025-0.10	0.025-0.12
K	0.025-0.15	0.035-0.17

Thread Size	Key	Clamping Torque (N.m)
S05	MX KEY-S05	7
S06	MX KEY-S06	10
S08	MX KEY-S08	15
S10	MX KEY-S10	28
S12	MX KEY-S12	28
S15	MX KEY-S15	40

Recommended Cutting Speed Vc(m/min)

ISO	Material Group	Hardness HB	Vc m/min
P	1	125	220-240
	2	190	170-200
	3-6	200	140-160
	7-8	300	110-130
	9-11	200	100-130
M	12-13	240	90-150
	14	180	70-100
K	15	180	70-240
	16	260	110-220
	17	170	130-250
	19	130	130-230
	20	230	100-200
N	21-24	90	600-700
S	33-35	350	10-20
	36-37		30-50
	38	HRC55	30-40
H	39	HRC60	25-30

High feed milling - MXFX Only

ISO	Material Group	Fz (mm/t) vs. Tool Diameter D(mm)							
		Ap	Ae	8	10	12	16	20	25
P	1	0.045xD	0.7xD	0.50	0.60	0.70	0.80	0.95	1.05
	2	0.045xD	0.7xD	0.50	0.60	0.70	0.80	0.95	1.05
	3	0.045xD	0.7xD	0.50	0.60	0.70	0.80	0.95	1.05
	4	0.045xD	0.7xD	0.50	0.60	0.70	0.80	0.95	1.05
	5	0.045xD	0.7xD	0.45	0.55	0.60	0.70	0.80	0.90
	6	0.045xD	0.7xD	0.35	0.45	0.50	0.60	0.70	0.80
	7	0.045xD	0.7xD	0.35	0.45	0.50	0.60	0.70	0.80
	8	0.045xD	0.7xD	0.35	0.40	0.45	0.55	0.65	0.75
	9	0.045xD	0.7xD	0.35	0.40	0.45	0.55	0.65	0.75
	10	0.04xD	0.6xD	0.30	0.35	0.40	0.50	0.6	0.70
	11	0.04xD	0.6xD	0.30	0.35	0.40	0.45	0.55	0.65
M	12-14	0.04xD	0.6xD	0.35	0.40	0.45	0.55	0.65	0.75
K	15-16	Apmax	0.7xD	0.50	0.55	0.65	0.75	0.85	0.95
	17-20	Apmax	0.7xD	0.40	0.50	0.55	0.65	0.75	0.85
H	38.1	0.035xD	0.45xD	0.25	0.30	0.35	0.45	0.50	0.60
	38.2	0.03xD	0.3xD	0.20	0.25	0.35	0.40	0.50	0.55
	39	0.02xD	0.25xD	0.15	0.20	0.20	0.25	0.25	0.30

Clamping Instructions

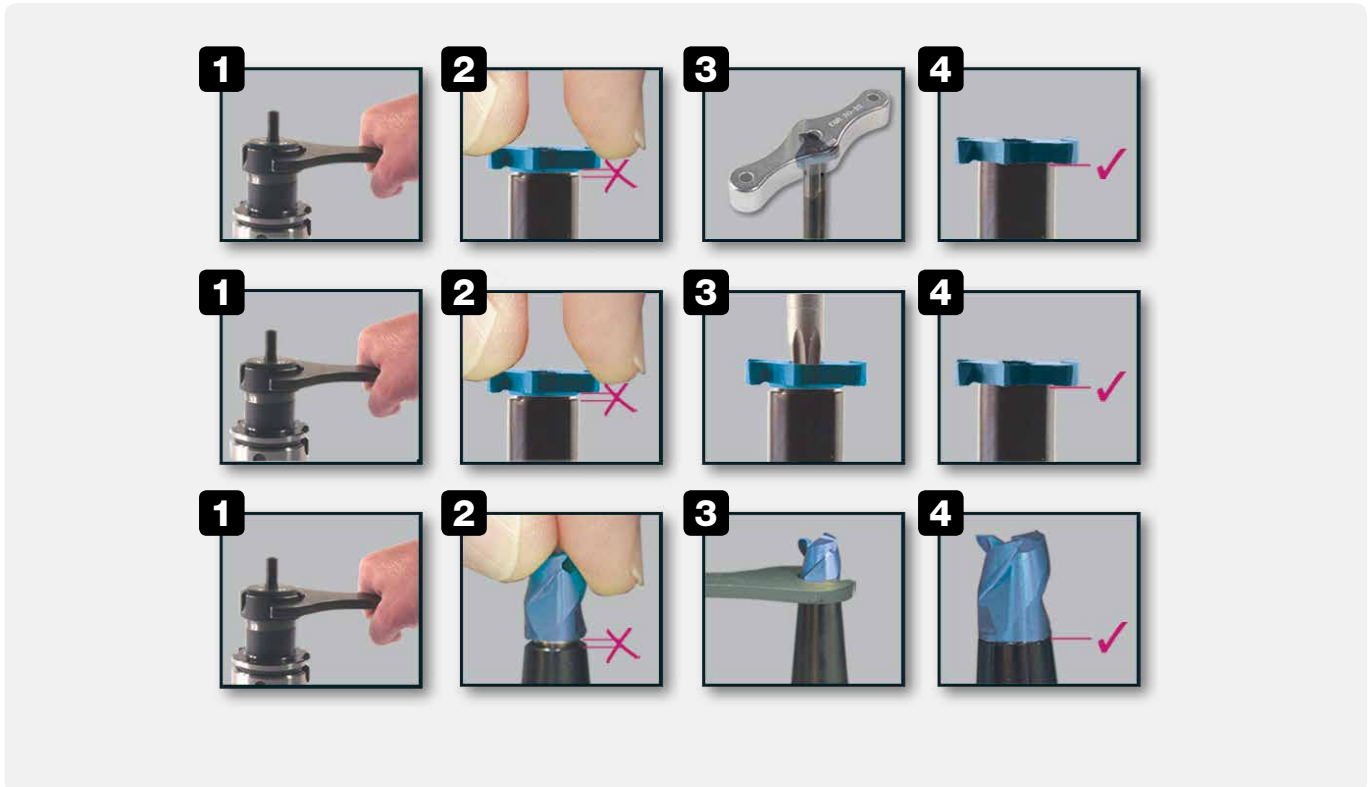

- Use TaeguTec cutting heads only
- Before mounting, clean the connection area of both the head and the holder
- Do not apply lubricant onto the connection areas
- Use the correct TT designated wrench (sold separately)
- Apply the proper clamping torque listed in this guide; excessive tightening may cause the cutting head to break

NPN

New Product News

expansion

MAXIRUSH

INDEXABLE SOLID HEADS

MAXI-RUSH Line Expanded



KEY POINT

TaeguTec has expanded the MAXI-RUSH line.

TaeguTec's innovative indexable head solid carbide end mill type, the MAXI-RUSH line, has been expanded.

The recently released MAXI-RUSH product line known for minimized set-up time, due to easy indexable head replacement with high rigidity, enables excellent machining precision.

With this expansion of the MAXI-RUSH line, customers now have a wider operation range to choose from.

Please contact the product manager for further technical questions.

MXEE-03

3 flute, for general purpose

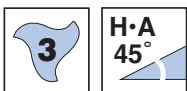
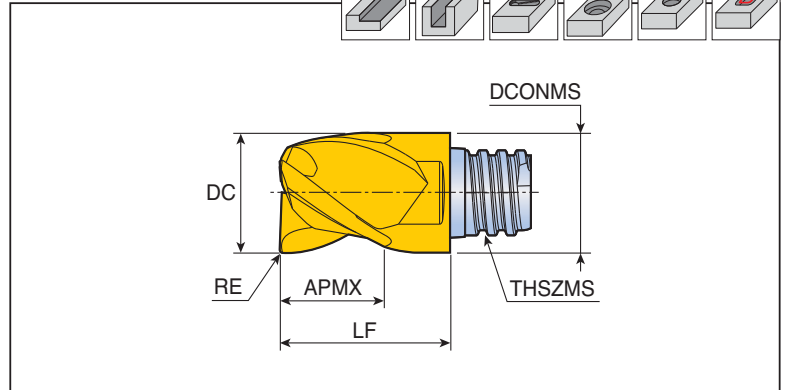
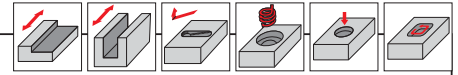

Designation	Feed (mm/tooth)	Dimension (mm)						Grade
		DC	RE	APMX	THSZMS	DCONMS	LF	
MXEE 080L05R00-03S05	0.030-0.080	8	-	5	S05	7.7	10	●
100L07R00-03S06	0.035-0.090	10	-	7	S06	9.7	13	●
120L09R00-03S08	0.035-0.110	12	-	9	S08	11.7	16.5	●

• Wrench should be ordered separately

●: Standard items

MXEE(D)-04

4 flute, for general purpose

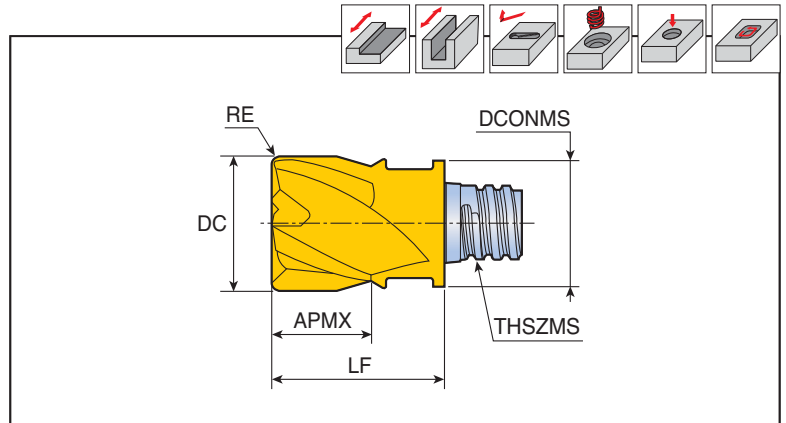
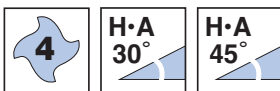

Designation	Feed (mm/tooth)	Dimension (mm)							Grade
		DC	RE	FHA	APMX	THSZMS	DCONMS	LF	
MXEE 060L05R00-04S05	0.025-0.060	6	-	45	5	S05	8.0	10	●
MXEE 080L05R00-04S05	0.030-0.080	8	-	45	5	S05	7.7	10	●
MXED 080L05R05-04S05	0.030-0.080	8	0.5	30	5	S05	7.7	10	●
MXED 080L05R10-04S05	0.030-0.080	8	1.0	30	5	S05	7.7	10	●
MXED 080L05R15-04S05	0.030-0.080	8	1.5	30	5	S05	7.7	10	●
MXEE 100L07R00-04S06	0.035-0.090	10	-	45	7	S06	9.7	13	●
MXED 100L07R05-04S06	0.035-0.090	10	0.5	30	7	S06	9.7	13	●
MXEE 100L07R05-04S06	0.035-0.090	10	0.5	45	7	S06	9.7	13	●
MXED 100L07R10-04S06	0.035-0.090	10	1.0	30	7	S06	9.7	13	●
MXEE 100L07R10-04S06	0.035-0.090	10	1.0	45	7	S06	9.7	13	●
MXEE 120L09R00-04S08	0.035-0.110	12	-	45	9	S08	11.7	16.5	●
MXED 120L09R05-04S08	0.035-0.110	12	0.5	30	9	S08	11.7	16.5	●
MXEE 120L09R05-04S08	0.035-0.110	12	0.5	45	9	S08	11.7	16.5	●
MXED 120L09R10-04S08	0.035-0.110	12	1.0	30	9	S08	11.7	16.5	●
MXEE 120L09R10-04S08	0.035-0.110	12	1.0	45	9	S08	11.7	16.5	●
MXEE 160L12R00-04S10	0.040-0.130	16	-	45	12	S10	15.3	20.5	●
MXED 160L12R05-04S10	0.040-0.130	16	0.5	30	12	S10	15.3	20.5	●
MXEE 160L12R05-04S10	0.040-0.130	16	0.5	45	12	S10	15.3	20.5	●
MXED 160L12R10-04S10	0.040-0.130	16	1.0	30	12	S10	15.3	20.5	●
MXEE 160L12R10-04S10 new	0.040-0.130	16	1.0	45	12	S10	15.3	20.5	●
MXED 160L12R15-04S10 new	0.040-0.130	16	1.5	30	12	S10	15.3	20.5	●
MXEE 160L12R15-04S10 new	0.040-0.130	16	1.5	45	12	S10	15.3	20.5	●
MXED 160L12R20-04S10 new	0.040-0.130	16	2.0	30	12	S10	15.3	20.5	●
MXEE 160L12R20-04S10 new	0.040-0.130	16	2.0	45	12	S10	15.3	20.5	●
MXEE 160L12R30-04S10 new	0.040-0.130	16	3.0	45	12	S10	15.3	20.5	●
MXEE 160L12R40-04S10	0.040-0.130	16	4.0	45	12	S10	15.3	20.5	●
MXEE 200L15R00-04S12	0.050-0.150	20	-	45	15	S12	18.3	25.5	●
MXED 200L15R05-04S12	0.050-0.150	20	0.5	30	15	S12	18.3	25.5	●
MXED 200L15R10-04S12	0.050-0.150	20	1.0	30	15	S12	18.3	25.5	●
MXED 200L15R20-04S12	0.050-0.150	20	2.0	30	15	S12	18.3	25.5	●
MXED 200L15R30-04S12	0.050-0.150	20	3.0	30	15	S12	18.3	25.5	●

- Wrench should be ordered separately
- FHA: Flute helix angle

●: Standard items

MXEE-03 new

3 flute, for keyways

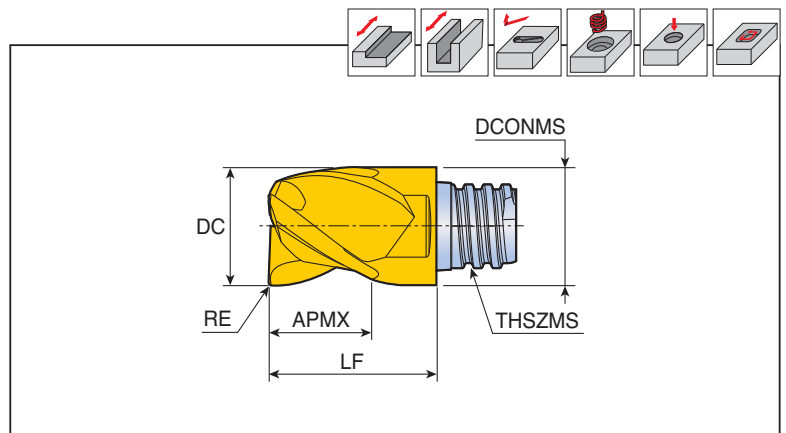

Designation	Feed (mm/tooth)	Dimension (mm)						Grade
		DC	RE	APMX	THSZMS	DCONMS	LF	
MXEE 077L04R02-03S05	0.030-0.080	7.7	0.2	4	S05	7.7	10	●
097L05R03-03S06	0.035-0.090	9.7	0.3	5	S06	9.7	13	●
117L07R03-03S08	0.035-0.110	11.7	0.3	7	S08	11.7	16.5	●
157L08R03-03S10	0.040-0.130	15.7	0.3	8	S10	15.3	20.5	●
197L12R04-03S12	0.050-0.150	19.7	0.4	12	S12	18.3	25.5	●

• Wrench should be ordered separately

●: Standard items

MXEE-I04

4 flute, unequal spacing of cutting edges (vibration free)

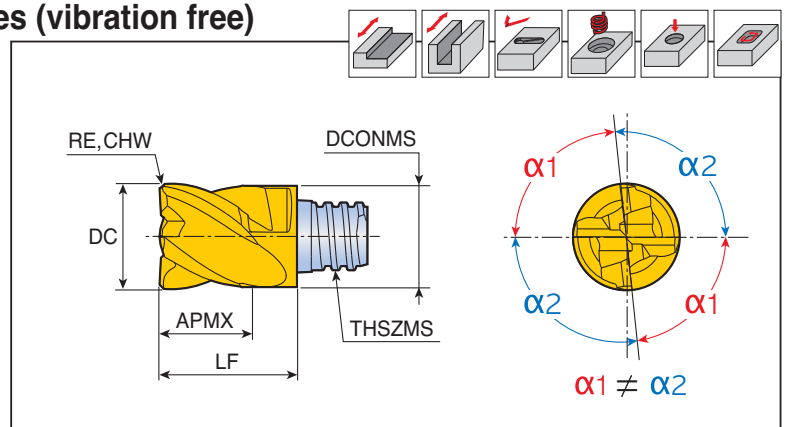
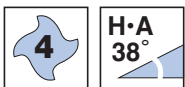

Designation	Feed (mm/tooth)	Dimension (mm)							Grade
		DC	RE	CHW	APMX	THSZMS	DCONMS	LF	
MXEE 080L05C30I04S05	0.030-0.080	8	-	0.3	5	S05	7.7	10	●
100L07C40I04S06	0.035-0.090	10	-	0.4	7	S06	9.7	13	●
120L09C50I04S08	0.035-0.110	12	-	0.5	9	S08	11.7	16.5	●
160L12C60I04S10	0.040-0.130	16	-	0.6	12	S10	15.3	20.5	●
200L15C60I04S12	0.050-0.150	20	-	0.6	15	S12	18.3	25.5	●
250L22C60I04S15 new	0.060-0.170	25	-	0.6	22	S15	23.9	37	●
250L22R00I04S15 new	0.060-0.170	25	-	-	22	S15	23.9	37	●
250L22R05I04S15 new	0.060-0.170	25	0.5	-	22	S15	23.9	37	●
250L22R10I04S15 new	0.060-0.170	25	1.0	-	22	S15	23.9	37	●
250L22R20I04S15 new	0.060-0.170	25	2.0	-	22	S15	23.9	37	●
250L22R30I04S15	0.060-0.170	25	3.0	-	22	S15	23.9	37	●

• Wrench should be ordered separately

●: Standard items

MXEE-R

4-6 flute, for roughing

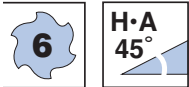
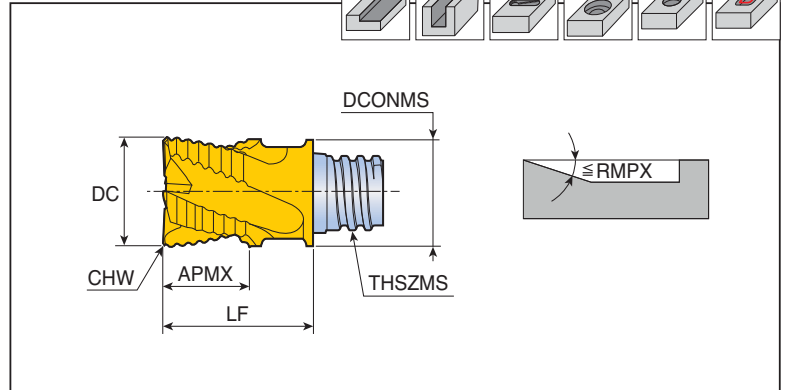
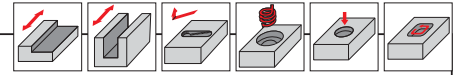

Designation	Feed (mm/tooth)	Dimension (mm)									Grade
		DC	NOF	APMX	CHW	THSZMS	DCONMS	LF	RMPX	TT5523	
MXEE 080L05C25R04S05	0.030-0.080	8	4	5	0.25	S05	7.7	10	90	●	
100L07C30R04S06	0.035-0.090	10	4	7	0.30	S06	9.7	13	90	●	
120L09C35R04S08	0.035-0.110	12	4	9	0.35	S08	11.7	16.5	90	●	
160L12C40R05S10	0.040-0.130	16	5	12	0.40	S10	15.3	20.5	7	●	
200L15C40R06S12	0.050-0.150	20	6	15	0.40	S12	18.3	25.5	3	●	
250L22C50R06S15	0.060-0.170	25	6	22	0.50	S15	23.9	37	3	●	

- Wrench should be ordered separately
- RMPX: Ramping angle maximum
- NOF: Number of flutes

●: Standard items

MXEE-C04

4 flute, combined edges for roughing & finishing

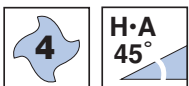
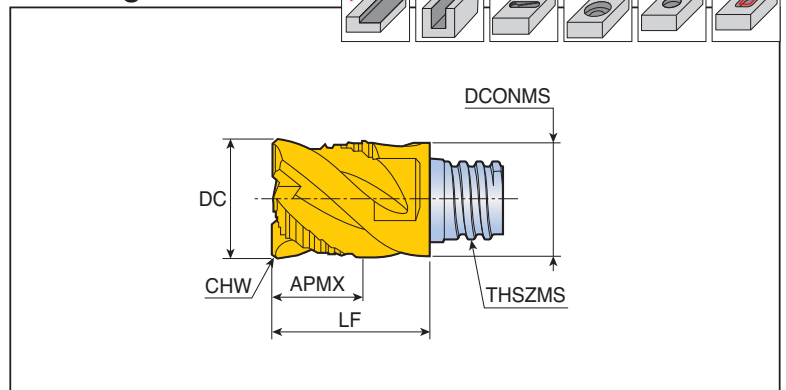
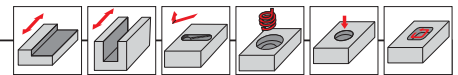

Designation	Feed (mm/tooth)	Dimension (mm)							Grade
		DC	APMX	CHW	THSZMS	DCONMS	LF	TT5523	
MXEE 080L05C30C04S05	0.030-0.080	8	5	0.3	S05	7.7	10	●	
100L07C30C04S06	0.035-0.090	10	7	0.3	S06	9.7	13	●	
120L09C40C04S08	0.035-0.110	12	9	0.4	S08	11.7	16.5	●	
160L12C60C04S10	0.040-0.130	16	12	0.6	S10	15.3	20.5	●	
200L15C60C04S12	0.050-0.150	20	15	0.6	S12	18.3	25.5	●	
250L22C60C04S15	0.060-0.170	25	22	0.6	S15	23.9	37	●	

- Wrench should be ordered separately

●: Standard items

MXEE-A02 new

2 flute, for aluminum machining

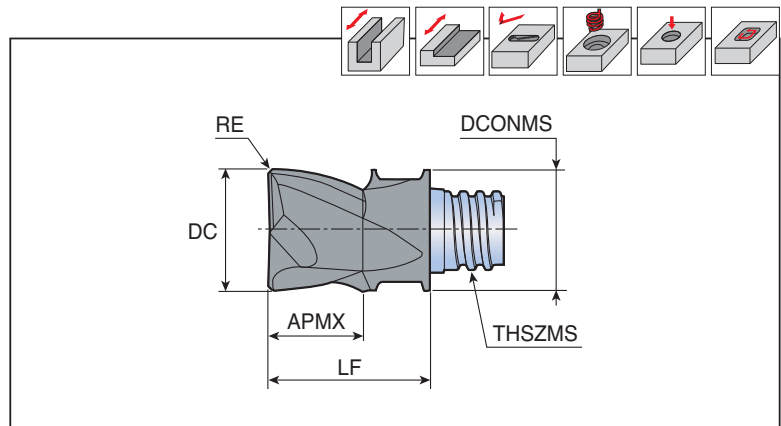
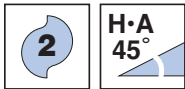

Designation	Feed (mm/tooth)	Dimension (mm)							Grade
		DC	RE	APMX	THSZMS	DCONMS	LF	UF10	
MXEE 100L07R05A02S06	0.035-0.090	10	0.5	7	S06	9.7	13	●	
100L07R10A02S06	0.035-0.090	10	1.0	7	S06	9.7	13	●	
120L09R05A02S08	0.035-0.110	12	0.5	9	S08	11.7	16.5	●	

• Wrench should be ordered separately

●: Standard items

MXEE-A03 new

3 flute, for aluminum machining

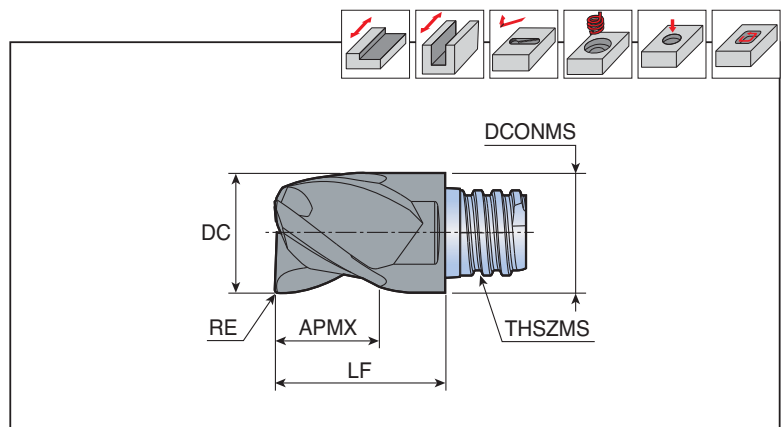
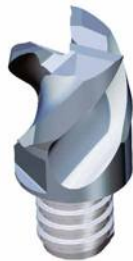

Designation	Feed (mm/tooth)	Dimension (mm)							Grade
		DC	RE	APMX	THSZMS	DCONMS	LF	UF10	
MXEE 080L05R05A03S05	0.030-0.080	8	0.5	5	S05	7.7	10	●	
100L06R05A03S06	0.035-0.090	10	0.5	6	S06	9.7	13	●	
100L06R10A03S06	0.035-0.090	10	1.0	6	S06	9.7	13	●	
120L08R05A03S08	0.035-0.110	12	0.5	8	S08	11.7	16.5	●	
120L08R10A03S08	0.035-0.110	12	1.0	8	S08	11.7	16.5	●	
160L10R00A03S10	0.040-0.130	16	-	10	S10	15.3	20.5	●	
160L10R10A03S10	0.040-0.130	16	1.0	10	S10	15.3	20.5	●	
160L10R20A03S10	0.040-0.130	16	2.0	10	S10	15.3	20.5	●	
200L12R05A03S12	0.050-0.150	20	0.5	12	S12	18.3	25.5	●	
200L12R10A03S12	0.050-0.150	20	1.0	12	S12	18.3	25.5	●	
200L12R20A03S12	0.050-0.150	20	2.0	12	S12	18.3	25.5	●	

• Wrench should be ordered separately

●: Standard items

MXRB-02 new

2 flute, 7° back taper flute

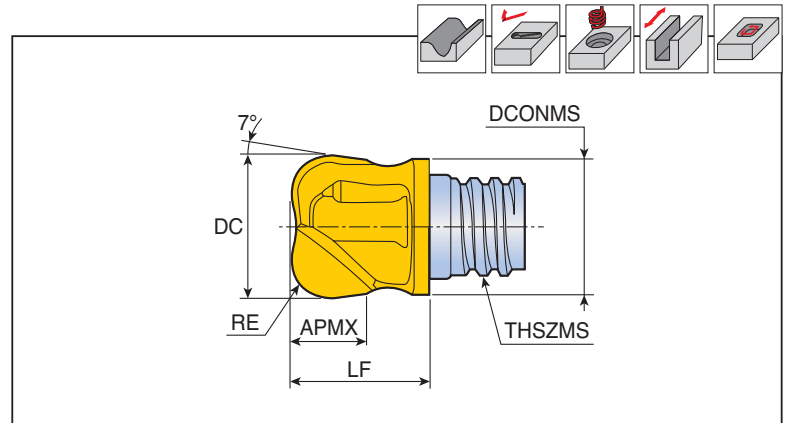

Designation	Feed (mm/tooth)	Dimension (mm)						Grade
		DC	RE	APMX	THSZMS	DCONMS	LF	
MXRB 200L11R50-02S12	0.05-0.150	20	5	11.3	S12	18.3	17.3	●

• Wrench should be ordered separately

●: Standard items

MXRD-06 new

6 flute, 7° back taper sided ground flute

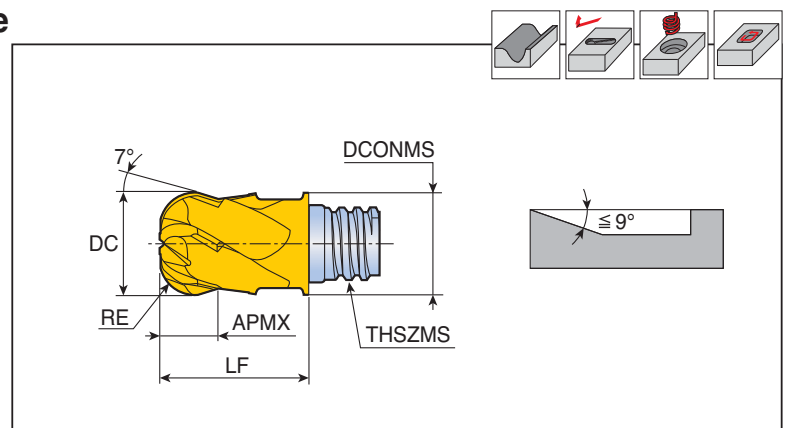

Designation	Feed (mm/tooth)	Dimension (mm)						Grade
		DC	RE	APMX	THSZMS	DCONMS	LF	
MXRD 080L04R20-06S05	0.030-0.080	8	2	4	S05	7.7	10	●
100L05R30-06S06	0.035-0.090	10	3	5	S06	9.7	13	●
120L07R40-06S08	0.035-0.110	12	4	7	S08	11.7	16.5	●
160L09R50-06S10	0.040-0.130	16	5	9	S10	15.3	20.5	●

• Wrench should be ordered separately

●: Standard items

MXFX-02



2 flute, for high feed milling

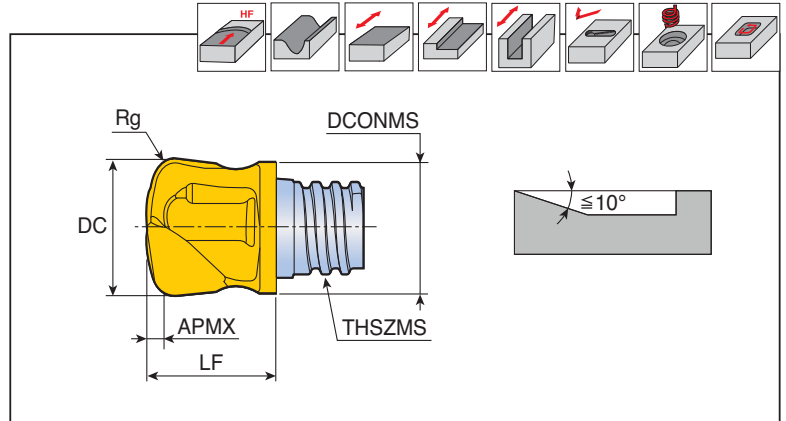

Designation	Feed (mm/tooth)	Dimension (mm)						Grade
		DC	Rg	APMX	THSZMS	DCONMS	LF	
MXFX 100L0.6R20-02S06	0.035-0.090	10	2.0	0.6	S06	9.6	12.5	●
120L01R25-02S08	0.035-0.110	12	2.5	1.0	S08	11.5	11.1	●
160L1.1R30-02S10	0.040-0.130	16	3.0	1.1	S10	15.2	20	●

- Wrench should be ordered separately
- Rg: Radius for programmers

●: Standard items

MXBD-BG-02



2 flute, for high precision machining

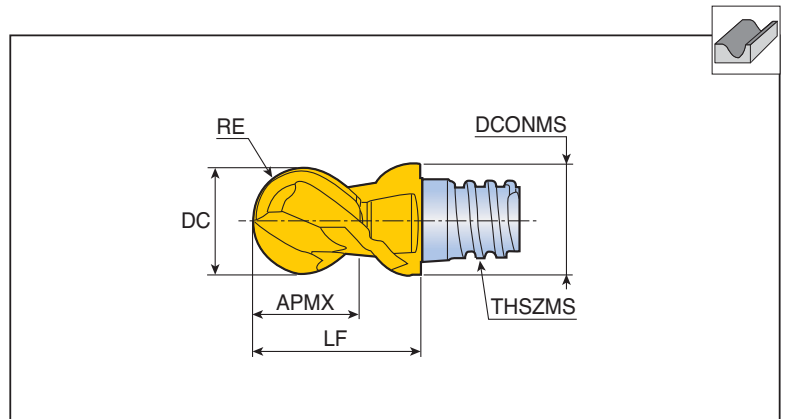

Designation	Feed (mm/tooth)	Dimension (mm)						Grade
		DC	Rg	APMX	THSZMS	DCONMS	LF	
MXBD 080L05-BG-02S05	0.030-0.080	8	3.982 ⁽¹⁾	5	S05	7.7	10	●
100L07-BG-02S06	0.035-0.090	10	4.982 ⁽¹⁾	7	S06	9.7	13	●
120L09-BG-02S08	0.035-0.110	12	5.978 ⁽²⁾	9	S08	11.7	16.5	●
160L09-BG-02S10	0.040-0.130	16	7.978 ⁽²⁾	9	S10	15.3	20.5	●

- Wrench should be ordered separately
- RE Tolerance: ⁽¹⁾± 0.01, ⁽²⁾± 0.012

●: Standard items

MXBD(E)-BG-04



4 flute, for high precision machining

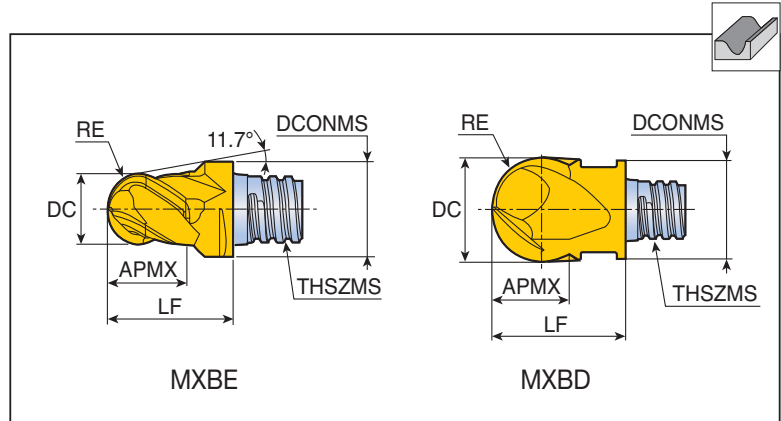

Designation	Feed (mm/tooth)	Dimension (mm)							Grade
		DC	RE	FHA	APMX	THSZMS	DCONMS	LF	
MXBE 06L05-BG-04S05	0.025-0.060	6	2.987 ⁽¹⁾	38	5.5	S05	8.0	10	●
MXBD 08L05-BG-04S05	0.030-0.080	8	3.982 ⁽¹⁾	30	5	S05	7.7	10	●
100L07-BG-04S06	0.035-0.090	10	4.982 ⁽¹⁾	30	7	S06	9.7	13	●
120L09-BG-04S08	0.035-0.110	12	5.978 ⁽²⁾	30	9	S08	11.7	16.5	●
160L12-BG-04S10	0.040-0.130	16	7.978 ⁽²⁾	30	12	S10	15.3	20.5	●
200L15-BG-04S12	0.050-0.150	20	9.972 ⁽²⁾	30	15	S12	18.3	25.5	●
250L22-BG-04S15	0.060-0.170	25	12.470 ⁽³⁾	30	22	S15	23.9	37	●

- Wrench should be ordered separately
- RE Tolerance: ⁽¹⁾± 0.01, ⁽²⁾± 0.012, ⁽³⁾± 0.02
- FHA: Flute helix angle

●: Standard items

MXBB-SG-02 new



2 flute, spherical designed edge

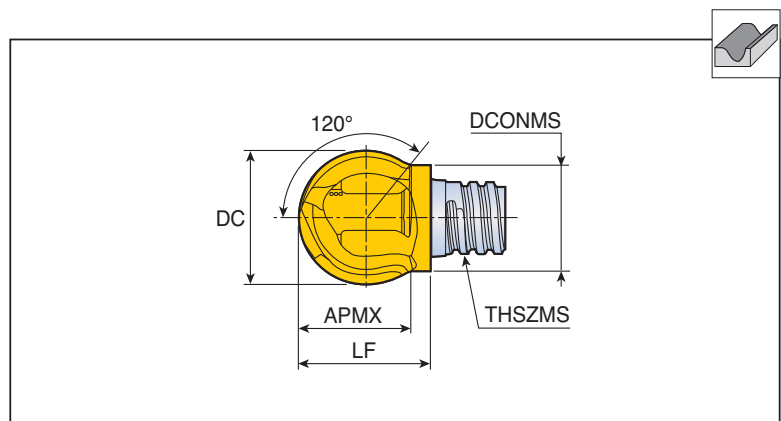

Designation	Feed (mm/tooth)	Dimension (mm)					Grade
		DC	APMX	THSZMS	DCONMS	LF	
* MXBB 120L09-SG-02S06	0.035-0.110	12	9.0	S06	9.5	11.6	●

- Wrench should be ordered separately
- * Use a different size wrench: MX KEY-S08

●: Standard items

MXBE-BGA02 new



2 flute, spherical designed edge for aluminum machining

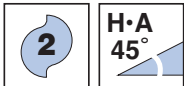
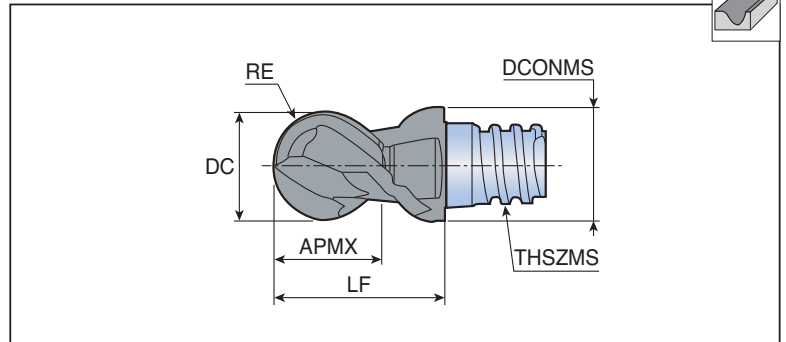

Designation	Feed (mm/tooth)	Dimension (mm)						Grade
		DC	RE	APMX	THSZMS	DCONMS	LF	
MXBE 080L05-BGA02S05	0.030-0.080	8	3.982 ⁽¹⁾	5	S05	7.7	10	•
100L07-BGA02S06	0.035-0.090	10	4.982 ⁽¹⁾	7	S06	9.7	13	•
120L09-BGA02S08	0.035-0.110	12	5.987 ⁽²⁾	9	S08	11.7	16.5	•
160L12-BGA02S10	0.040-0.130	16	7.978 ⁽²⁾	12	S10	15.3	20.5	•
200L15-BGA02S12	0.050-0.150	20	9.972 ⁽²⁾	15	S12	18.3	25.5	•

- Wrench should be ordered separately
- RE Tolerance: ⁽¹⁾± 0.01, ⁽²⁾± 0.012

• Standard items

MXCP-02



2 flute, for spot drilling, chamfering and countersinking

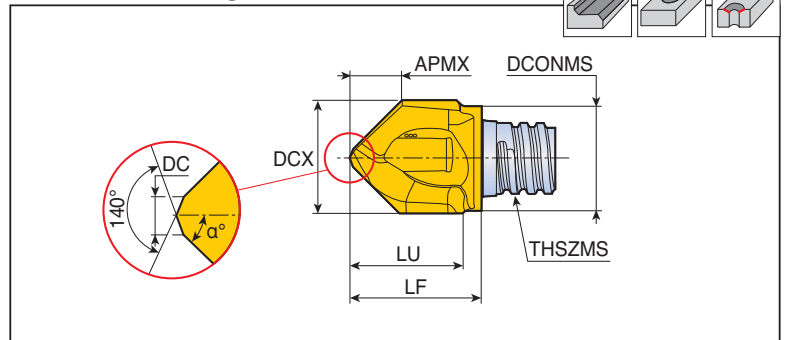

Designation	Feed (mm/tooth)	Dimension (mm)								Grade
		DCX	DC	APMX	THSZMS	DCONMS	LU	LF	α°	
MXCP 100L09A30-02S06	0.035-0.090	10	1.5	7.5	S06	9.5	8.5	11.75	30	•
120L12A30-02S08	0.035-0.110	12	1.5	9.2	S08	11.5	11	15.4	30	•
160L15A30-02S10	0.040-0.130	16	2.5	12	S10	15.2	16	20.2	30	•
080L07A45-02S05	0.030-0.080	8	1.0	3.7	S05	7.6	7.5	9.75	45	•
083L07A45-02S05	0.030-0.080	8.3	1.0	3.8	S05	7.6	7.5	10	45	•
100L09A45-02S06	0.035-0.090	10	1.5	4.4	S06	9.5	9.5	11.75	45	•
104L09A45-02S06	0.035-0.090	10.4	1.5	4.6	S06	9.5	9.5	11.75	45	•
120L12A45-02S08	0.035-0.110	12	1.5	5.4	S08	11.5	11.5	15.4	45	•
124L12A45-02S08	0.035-0.110	12.4	1.5	5.6	S08	11.5	11.5	15.4	45	•
160L15A45-02S10	0.040-0.130	16	1.5	7.1	S10	15.2	15	18.8	45	•
165L15A45-02S10	0.040-0.130	16.5	1.5	7.1	S10	15.2	15	18.8	45	•
100L09A60-02S06	0.035-0.090	10	1.5	2.7	S06	9.5	9.5	12.7	60	•
120L12A60-02S08	0.035-0.110	12	1.5	3.3	S08	11.5	11.5	15.2	60	•
160L15A60-02S10	0.040-0.130	16	1.5	4.4	S10	15.2	16	19.9	60	•

- Wrench should be ordered separately

• Standard items

MXDP-02



2 flute, for center drilling

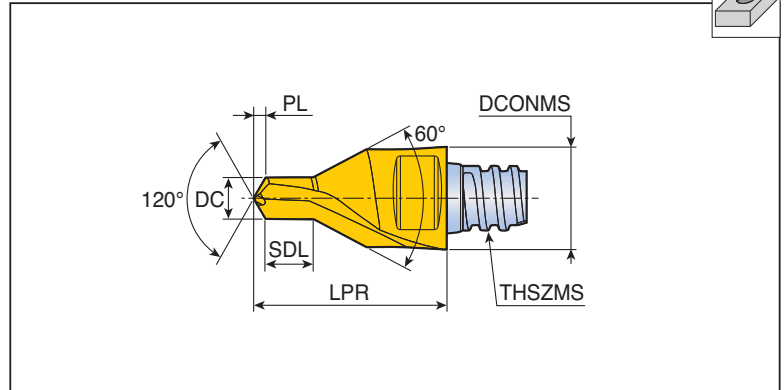

Designation	Feed (mm/tooth)	Dimension (mm)							Grade
		DC	PL	SDL	THSZMS	DCONMS	LPR	TT5523	
MXDP 328L04A30-02S05	0.04-0.08	3.28	0.85	3.75	S05	8	15	●	
412L05A30-02S06	0.05-0.10	4.12	1.07	4.83	S06	10	19	●	
513L07A30-02S08	0.05-0.12	5.13	1.32	5.88	S08	12	23	●	
646L08A30-02S10	0.06-0.15	6.46	1.65	7.25	S10	16	28	●	

- Wrench should be ordered separately
- SDL: Step diameter length

●: Standard items

MXGC-02 new



2 flute, for counter boring

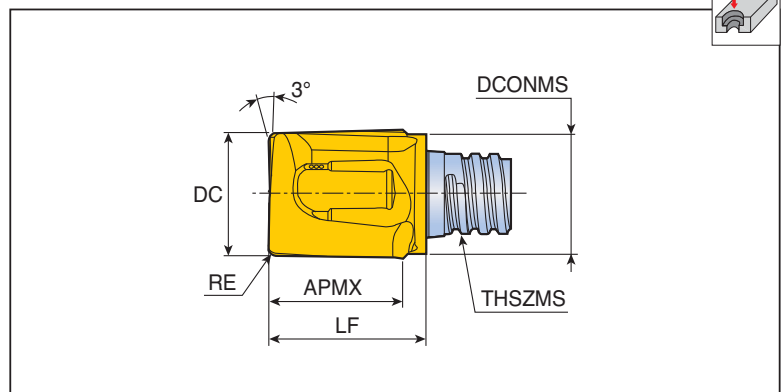

Designation	Feed (mm/tooth)	Dimension (mm)							Grade
		DC	RE	APMX	THSZMS	DCONMS	LF	TT5523	
MXGC 080L08R04-02S05	0.030-0.080	8	0.4	7.7	S05	7.6	10	●	
080L08R10-02S05	0.030-0.080	8	1.0	7.7	S05	7.6	10	●	
100L09R04-02S06	0.035-0.090	10	0.4	9.0	S06	9.5	12.4	●	
100L09R20-02S06	0.035-0.090	10	2.0	9.0	S06	9.5	12.4	●	
120L10R04-02S08	0.035-0.110	12	0.4	10	S08	11.5	14.2	●	
120L10R10-02S08	0.035-0.110	12	1.0	10	S08	11.5	14.2	●	
120L10R20-02S08	0.035-0.110	12	2.0	10	S08	11.5	14.2	●	
160L15R04-02S10	0.040-0.130	16	0.4	14.9	S10	15.2	19	●	

- Wrench should be ordered separately

●: Standard items

MXCA-04/06



4, 6 flute, chamfering and countersinking without central edge

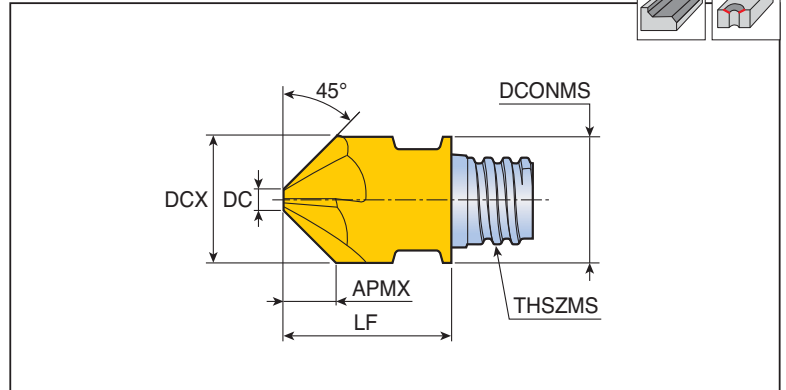
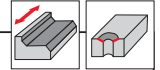

Designation	Feed (mm/tooth)	Dimension (mm)								Grade
		DCX	DC	NOF	APMX	THSZMS	DCONMS	LF	TT5523	
MXCA 100L04A45-04S06	0.035-0.090	10	1.95	4	4.0	S06	10	13	●	
120L05A45-04S08	0.035-0.110	12	1.95	4	5.0	S08	12	16.5	●	
127L05A45-04S08	0.035-0.110	12.7	1.98	4	5.3	S08	12.7	16.5	●	
160L06A45-06S10	0.040-0.130	16	3.0	6	6.5	S10	16	20.3	●	
200L07A45-06S12	0.050-0.150	20	5.0	6	7.5	S12	20	25.5	●	

- Wrench should be ordered separately
- NOF: Number of flutes

●: Standard items

MXCW-02



2 flute, for double chamfering

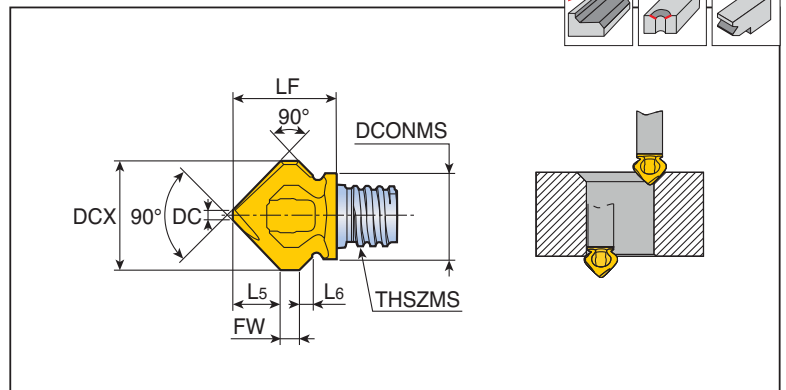
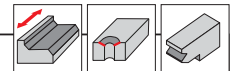

Designation	Feed (mm/tooth)	Dimension (mm)								Grade
		DCX	DC	L5	L6	FW	THSZMS	DCONMS	LF	
* MXCW 118L05A45-02S06	0.035-0.110	11.8	1.2	5	1.2	2	S06	9.3	11.2	●

- Wrench should be ordered separately
- * Use a different size wrench: MX KEY-08

●: Standard items

TST-4/6

4, 6 flute, for slotting

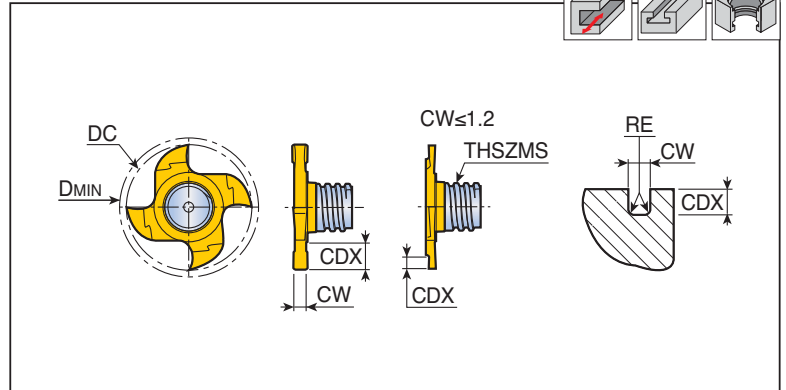
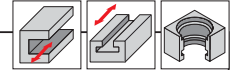

Designation	Feed (mm/tooth)	Dimension (mm)							Torx	Grade TT5543
		DC	NOF	CW	CDX	RE	THSZMS	DMIN		
TST 217W0.76R000-4S08 <small>new</small>	0.025-0.100	21.7	4	0.76 ⁽¹⁾	1.5	-	S08	22.0	-	●
217W0.96R000-4S08 <small>new</small>	0.025-0.100	21.7	4	0.96 ⁽¹⁾	1.9	-	S08	22.0	-	●
217W1.0R005-4S08 <small>new</small>	0.025-0.100	21.7	4	1.0	2	0.05	S08	22.0	-	●
217W1.20R005-4S08 <small>new</small>	0.025-0.120	21.7	4	1.2 ⁽¹⁾	4.5	0.05	S08	22.0	-	●
217W1.40R005-4S08 <small>new</small>	0.025-0.120	21.7	4	1.4 ⁽¹⁾	4.5	0.05	S08	22.0	-	●
217W1.57R000-4S08 <small>new</small>	0.025-0.120	21.7	4	1.57	4.5	-	S08	22.0	-	●
217W1.70R010-4S08 <small>new</small>	0.025-0.120	21.7	4	1.7 ⁽¹⁾	4.5	0.1	S08	22.0	-	●
217W1.95R020-4S08	0.025-0.120	21.7	4	1.95 ⁽¹⁾	4.5	0.2	S08	22.0	-	●
217W2.0R020-4S08	0.025-0.120	21.7	4	2.0	4.5	0.2	S08	22.0	-	●
217W2.25R020-4S08 <small>new</small>	0.025-0.120	21.7	4	2.25 ⁽¹⁾	4.5	0.2	S08	22.0	-	●
217W2.39R020-4S08 <small>new</small>	0.025-0.120	21.7	4	2.39	4.5	0.2	S08	22.0	-	●
217W2.50R020-4S08	0.025-0.120	21.7	4	2.5	4.5	0.2	S08	22.0	-	●
217W2.75R020-4S08	0.025-0.130	21.7	4	2.75 ⁽¹⁾	4.5	0.2	S08	22.0	-	●
217W3.0R020-4S08	0.025-0.130	21.7	4	3.0	4.5	0.2	S08	22.0	-	●
217W3.17R020-4S08 <small>new</small>	0.025-0.150	21.7	4	3.17	4.5	0.2	S08	22.0	-	●
217W3.25R020-4S08 <small>new</small>	0.025-0.150	21.7	4	3.25 ⁽¹⁾	4.5	0.2	S08	22.0	-	●
217W4.0R020-4S08	0.025-0.150	21.7	4	4.0	4.5	0.2	S08	22.0	-	●
217W4.25R020-4S08	0.025-0.150	21.7	4	4.25 ⁽¹⁾	4.5	0.2	S08	22.0	-	●
217W4.75R020-4S08 <small>new</small>	0.025-0.150	21.7	4	4.75	4.5	0.2	S08	22.0	-	●
217W5.25R020-4S08 <small>new</small>	0.025-0.170	21.7	4	5.25 ⁽¹⁾	4.5	0.2	S08	22.0	-	●
277W2.50R020-6S10	0.025-0.120	27.7	6	2.5	6	0.2	S10	28.0	T40	●
277W5.25R020-6S10	0.025-0.170	27.7	6	5.25	6	0.2	S10	28.0	T40	●
277W10R020-6S10	0.025-0.170	27.7	6	10.0	6	0.2	S10	28.0	T40	●

- Wrench should be ordered separately
- NOF: Number of flutes
- ⁽¹⁾ CW for circle clips according to DIN 471/472

●: Standard items

TST-A45 new



3, 4 flute, for chamfering

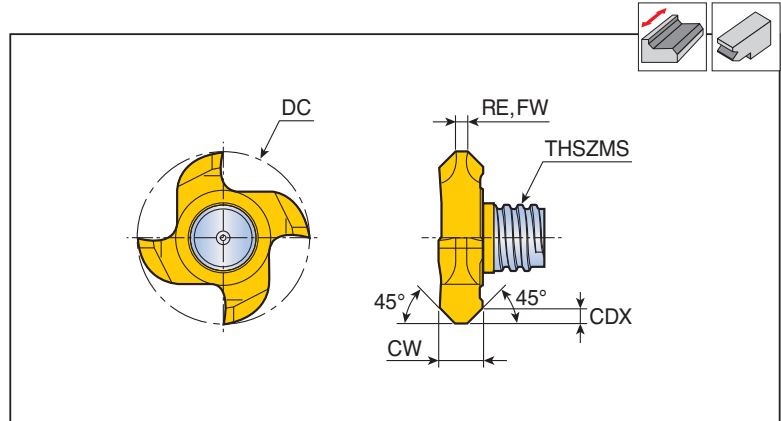

Designation	Feed (mm/tooth)	Dimension (mm)							Grade
		DC	NOF	CW	CDX	RE	FW	THSZMS	
TST 177L01.40A45-3S06	0.025-0.150	17.7	3	3.4	1.4	0.1	-	S06	●
217L01.70A45-4S08	0.025-0.170	21.7	4	5.5	1.7	-	1.5	S08	●

- Wrench should be ordered separately
- NOF: Number of flutes
- FW: Flat width

●: Standard items

TTB-C15 new



6 flute, for chamfered slotting

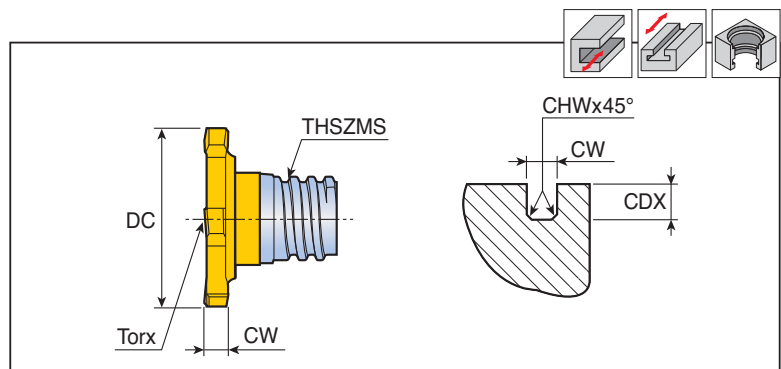

Designation	Feed (mm/tooth)	Dimension (mm)					Torx	Grade
		DC	CW	CDX	CHW	THSZMS		
TTB 135W2.0C15-06S05	0.025-0.120	13.5	2	2.65	0.15	S05	T20	●

- Wrench should be ordered separately
- CHW: Corner chamfer width

●: Standard items

MXSSD



Straight shanks with neck

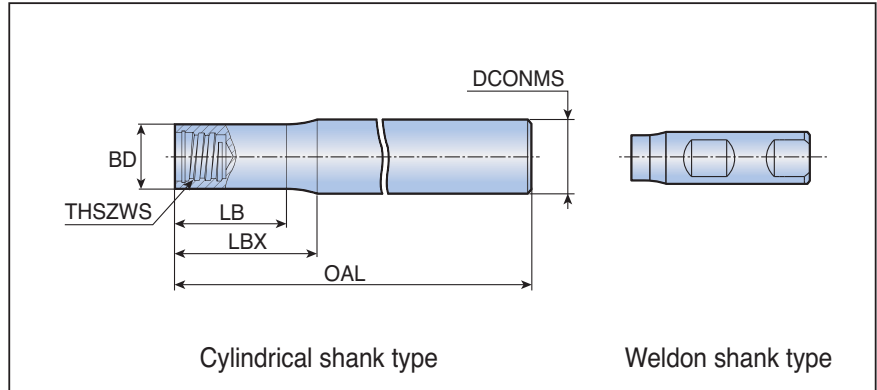

Cylindrical shank type

Weldon shank type

Designation	Dimension (mm)						Shank type	Shank material
	THSZWS	DCONMS	BD	OAL	LB	LBX		
MXSSD 08L060S05-S	S05	8	7.6	60	12.8	15	Cylindrical	Steel
08L070S05-C	S05	8	7.6	70	19	20	Cylindrical	Carbide
08L090S05-C	S05	8	7.6	90	39	40	Cylindrical	Carbide
08L110S05-C	S05	8	7.6	110	59	60	Cylindrical	Carbide
10L070S06-C	S06	10	9.6	70	18.5	20	Cylindrical	Carbide
10L075S06-S	S06	10	9.6	75	17.7	20	Cylindrical	Steel
10L090S06-C	S06	10	9.6	90	38.5	40	Cylindrical	Carbide
10L110S06-C	S06	10	9.6	110	58.5	60	Cylindrical	Carbide
10L150S06-C	S06	10	9.6	150	98.5	100	Cylindrical	Carbide
12L055W05-S	S05	12	7.6	55	-	3.8	Weldon	Steel
12L070S08-C	S08	12	11.5	70	17	20	Cylindrical	Carbide
12L090S08-C	S08	12	11.5	90	37	40	Cylindrical	Carbide
12L090S08-S	S08	12	11.5	90	13.6	16	Cylindrical	Steel
12L110S08-C	S08	12	11.5	110	57	60	Cylindrical	Carbide
12L130S08-C	S08	12	11.5	130	77	80	Cylindrical	Carbide
16L065W06-S	S06	16	9.6	65	-	6	Weldon	Steel
16L065W08-S	S08	16	11.5	65	-	4	Weldon	Steel
16L090S10-C	S10	16	15.2	90	38	40	Cylindrical	Carbide
16L100S10-S	S10	16	15.2	100	18	20	Cylindrical	Steel
16L110S10-C	S10	16	15.2	110	58	60	Cylindrical	Carbide
16L130S10-C	S10	16	15.2	130	78	80	Cylindrical	Carbide
16L150S10-C	S10	16	15.2	150	98	100	Cylindrical	Carbide
20L070W10-S	S10	20	15.2	70	-	4	Weldon	Steel
20L090S12-C	S12	20	18.3	90	37	40	Cylindrical	Carbide
20L120S12-S	S12	20	18.3	120	20.5	25	Cylindrical	Steel
20L130S12-C	S12	20	18.3	130	77	80	Cylindrical	Carbide
20L200S12-C new	S12	20	18.3	200	117	120	Cylindrical	Carbide
25L075W12-S new	S12	25	18.3	75	-	6	Weldon	Steel
25L120S15-C new	S15	25	23.9	120	58	60	Cylindrical	Carbide
25L135S15-S new	S15	25	23.9	135	33	35	Cylindrical	Steel
25L170S15-C new	S15	25	23.9	170	98	100	Cylindrical	Carbide
25L250S15-C new	S15	25	23.9	250	148	150	Cylindrical	Carbide

• THSZWS: Connection thread size

MXTSD



Straight shanks with taper neck

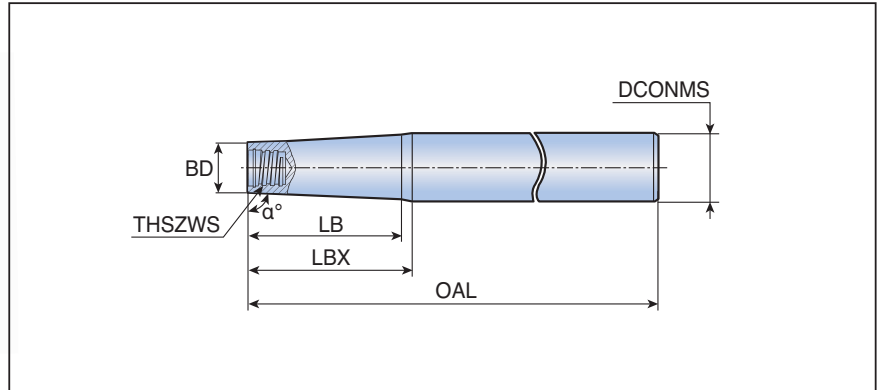

Designation	Dimension (mm)							Shank material
	α°	THSZWS	DCONMS	BD	OAL	LB	LBX	
MXTSD 12L080S05-S	85	S05	12	7.6	80	-	25	Steel
12L100S05-S	89	S05	12	7.6	100	31.0	35	Steel
12L110S05-C	89	S05	12	7.6	110	58.0	60	Carbide
12L130S05-C	89	S05	12	7.6	130	79.0	80	Carbide
16L125S06-S	85	S06	16	9.6	125	31.6	34	Steel
16L130S08-C	89	S08	16	11.5	130	78.8	80	Carbide
16L140S08-S	85	S08	16	11.5	140	19.3	22	Steel
16L150S05-C	89	S05	16	7.6	150	96.0	100	Carbide
16L150S06-C	89	S06	16	9.6	150	98.0	100	Carbide
16L150S08-C	89	S08	16	11.5	150	-	100	Carbide
16L160S06-S	89	S06	16	9.6	160	45.9	55	Steel
16L170S06-C	89	S06	16	9.6	170	119.0	120	Carbide
20L140S10-S	85	S10	20	15.2	140	-	27.5	Steel
20L170S08-C	89	S08	20	11.5	170	117.0	120	Steel
20L170S08-S	89	S08	20	11.5	170	68.6	80	Steel
20L170S10-C	89	S10	20	15.2	170	-	120	Carbide
20L190S10-C	89	S10	20	15.2	190	-	140	Carbide
20L190S10-S	89	S10	20	15.2	190	73.0	80	Steel
20L210S10-C	89	S10	20	15.2	210	-	160	Carbide
25L160S12-S	85	S12	25	18.3	160	-	40	Steel
25L170S10-S	85	S10	25	15.2	170	-	56	Steel
25L180S12-C	89	S12	25	18.3	180	-	120	Carbide
25L210S12-S	89	S12	25	18.3	210	91.0	100	Steel
25L250S12-C	89	S12	25	18.3	250	-	140	Carbide
32L155S15-S	85	S15	32	23.9	155	40.0	45	Steel
32L190S12-S	85	S12	32	18.3	190	-	80	Steel
32L220S15-S new	85	S15	32	23.9	220	-	100	Steel
32L250S15-C new	89	S15	32	23.9	250	-	150	Carbide
32L300S15-C new	89	S15	32	23.9	300	-	200	Carbide

• THSZWS: Connection thread size

MXTSD-W-A new



Straight tungsten shanks with taper neck & internal coolant hole

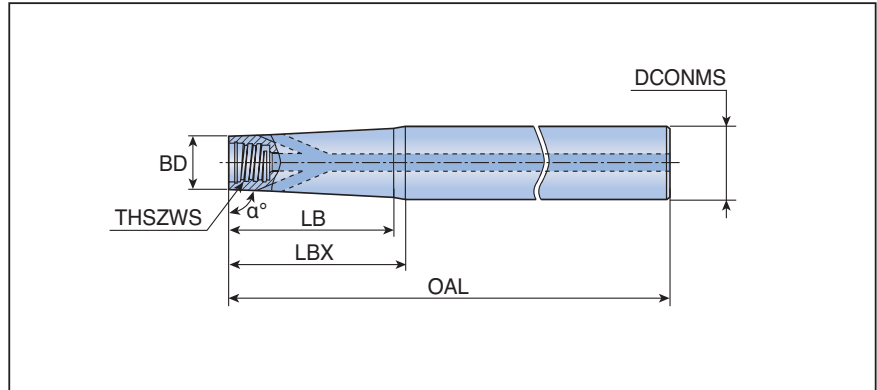

Designation	Dimension (mm)							Shank material
	α°	THSZWS	DCONMS	BD	OAL	LB	LBX	
MXTSD 12L110S06-W-A	89	S06	12	9.6	110	59	60	Tungsten
16L170S06-W-A	89	S06	16	9.6	170	116	120	Tungsten

• THSZWS: Connection thread size

MXSC-C



Straight carbide shanks for TST & TTB slotting head

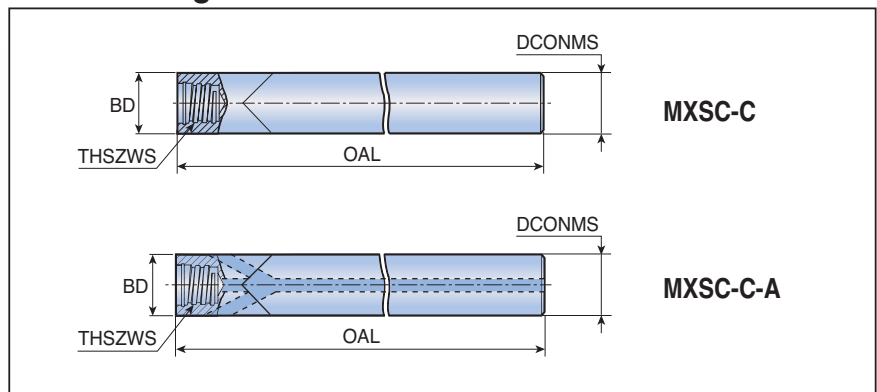

Designation	Dimension (mm)				Coolant hole	Shank material
	THSZWS	DCONMS	BD	OAL		
MXSC 100L100S06-C	S06	10	10	100	X	Carbide
120L100S08-C-A	S08	12	12	100	○	Carbide

• THSZWS: Connection thread size

Note:

• For MXSC type shank, it is recommended to use the TST & TTB slotting head only. If other heads are used on the MXSC shank, the depth of cut must be smaller than the max. ap in each head. The MXSC type shank does not have external clearance, so the shank may interfere with the work piece.

MXSTD



Straight shanks for TST & TTB slotting head

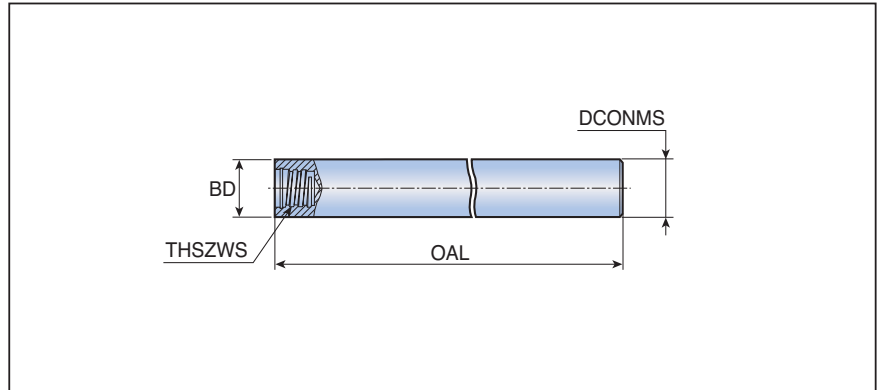

Designation	Dimension (mm)				Shank material
	THSZWS	DCONMS	BD	OAL	
MXSTD 08L070S05-S	S05	8	8	70	Steel
10L080S06-S	S06	10	10	80	Steel
12L090S08-S	S08	12	12	90	Steel
16L100S10-S	S10	16	16	100	Steel

• THSZWS: Connection thread size

Note:

• For MXSTD type shank, it is recommended to use the TST & TTB slotting head only. If other heads are used on the MXSTD shank, the depth of cut must be smaller than the max. ap in each head. The MXSTD type shank does not have external clearance, so the shank may interfere with the work piece.

MXAD-M new



Adapters for T-FLEXTEC

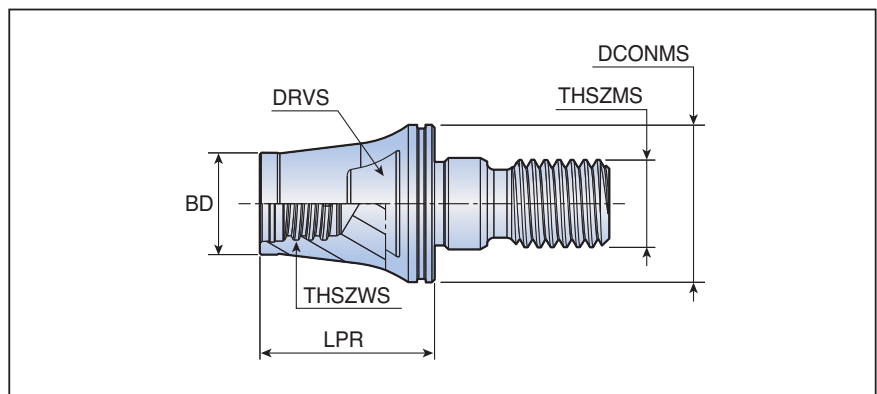



Designation	Dimension (mm)						Shank material
	THSZWS	THSZMS	DCONMS	BD	LPR	DRVS	
MXAD 130L016S08-S-M8	S08	M8	13	11.7	16	11	Steel
130L025S08-S-M8	S08	M8	13	11.7	25	11	Steel
180L020S08-S-M10	S08	M10	18	11.7	20	13	Steel
180L025S08-S-M10	S08	M10	18	11.7	25	11	Steel
210L020S08-S-M12	S08	M12	21	11.7	20	12.75	Steel
210L025S08-S-M12	S08	M12	21	11.7	25	12.75	Steel

• THSZWS: Connection thread size

• DRVS: Clamping wrench size

Wrench

Appearance	Designation	Connection thread size	Torque (N.m)	Head
	MX KEY-S05	S05	7	Square Ball Round Drilling Chamfering Counter boring
	MX KEY-S06	S06	10	
	MX KEY-S08	S08	15	
	MX KEY-S10	S10	28	
	MX KEY-S12	S12	28	
	MX KEY-S15	S15	40	
	MX SKEY-S06	S06	10	Slotting TST type
	MX SKEY-S08	S08	15	
	MX SKEY-T40L	S08	15	Slotting TST, TTB type
		S10	28	
	MX SKEY-T20	S05	7	
		S06	10	
	MX SKEY-T25	S06	10	
	MX SKEY-T30L	S08	15	
	MX SKEY-T50L	S08	15	
		S10	28	

• Wrench should be ordered separately

Torque wrench

Appearance	Designation	Connection	TM head designation	Torque (N.m)
Handle	TORQUE WRENCH 5-50Nm 9X12			
Open wrench for cylindrical head	MX WRENCH 6-05	S05	MXED, MXEE MXRD, MXBE MXDP, MXCA	7
	MX WRENCH 8-06	S06		10
	MX WRENCH 10-08	S08		15
	MX WRENCH 13-10	S10		28
	MX WRENCH 16-12	S12		28
	MX WRENCH 20-15	S15		40
Open wrench for 2 flutes head	MX WRENCH 4E-05	S05	MXRB, MXFX MXBB MXCP, MXGC MXCW, MXCR	7
	MX WRENCH 5E-06	S06		10
	MX WRENCH 7E-08	S08		15
	MX WRENCH 8E-10	S10		28
	MX WRENCH 9E-12	S12		28
90° adapter for torx bit	INSERT TOOL 9X12MM			
Torx bit socket	BIT SOCKET T20 DRIVE	S05, S06	TTB TST277	7, 10
	BIT SOCKET T25 DRIVE	S06		10
	BIT SOCKET T30 DRIVE	S08		15
	BIT SOCKET T40 DRIVE	S08, S10		15, 28
	BIT SOCKET T50 DRIVE	S08, S10		15, 28

• Wrench should be ordered separately

Recommended Cutting Conditions

fz for Square & Round heads (mm/tooth)

Slotting
 $ap \leq 0.5D$
 $ae \leq D$

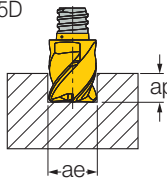

Side Milling

$ae \leq 0.5D$

(1) $ap \leq D$

(2) $ap \leq 0.05D$

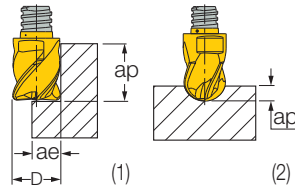

D (mm)	fz (mm/tooth)	D (mm)	fz (mm/tooth)
6	0.027-0.05	6	0.027-0.06
8	0.032-0.07	8	0.032-0.08
10	0.034-0.08	10	0.034-0.09
12	0.036-0.10	12	0.036-0.11
16	0.050-0.12	16	0.05 - 0.13
20	0.052-0.14	20	0.052-0.15
25	0.062-0.15	25	0.062-0.17

fz for Slotting heads (mm/tooth)

ISO

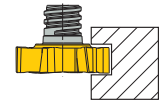
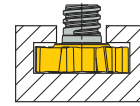

P	0.025-0.12	0.035-0.15
M	0.025-0.10	0.025-0.12
K	0.025-0.15	0.035-0.17
Thread Size	Key	Clamping Torque (N.m)
S05	MX KEY-S05	7
S06	MX KEY-S06	10
S08	MX KEY-S08	15
S10	MX KEY-S10	28
S12	MX KEY-S12	28
S15	MX KEY-S15	40

Recommended Cutting Speed

ISO	Material No.	Hardness HB	Vc (m/min)
P	1	125	220-240
	2	190	170-200
	3-6	200	140-160
	7-8	300	110-130
	9-11	200	100-130
M	12-13	240	90-150
	14	180	70-100
K	15	180	70-240
	16	260	110-220
	17	170	130-250
	19	130	130-230
	20	230	100-200
N	21-24	90	600-700
S	33-35	350	10-20
	36-37	-	30-50
H	38	HRC55	30-40
	39	HRC60	25-30

High feed milling - MXFX Only

ISO	Material No.	Depth of cut (ap)	Width of cut (ae)	fz (mm/tooth) vs. Tool Diameter D (mm)					
				Ø8	Ø10	Ø12	Ø16	Ø20	Ø25
P	1	0.045xD	0.7xD	0.50	0.60	0.70	0.80	0.95	1.05
	2	0.045xD	0.7xD	0.50	0.60	0.70	0.80	0.95	1.05
	3	0.045xD	0.7xD	0.50	0.60	0.70	0.80	0.95	1.05
	4	0.045xD	0.7xD	0.50	0.60	0.70	0.80	0.95	1.05
	5	0.045xD	0.7xD	0.45	0.55	0.60	0.70	0.80	0.90
	6	0.045xD	0.7xD	0.35	0.45	0.50	0.60	0.70	0.80
	7	0.045xD	0.7xD	0.35	0.45	0.50	0.60	0.70	0.80
	8	0.045xD	0.7xD	0.35	0.40	0.45	0.55	0.65	0.75
	9	0.045xD	0.7xD	0.35	0.40	0.45	0.55	0.65	0.75
	10	0.04xD	0.6xD	0.30	0.35	0.40	0.50	0.6	0.70
	11	0.04xD	0.6xD	0.30	0.35	0.40	0.45	0.55	0.65
M	12-14	0.04xD	0.6xD	0.35	0.40	0.45	0.55	0.65	0.75
K	15-16	A _{pmax}	0.7xD	0.50	0.55	0.65	0.75	0.85	0.95
	17-20	A _{pmax}	0.7xD	0.40	0.50	0.55	0.65	0.75	0.85
H	38.1	0.035xD	0.45xD	0.25	0.30	0.35	0.45	0.50	0.60
	38.2	0.03xD	0.3xD	0.20	0.25	0.35	0.40	0.50	0.55
	39	0.02xD	0.25xD	0.15	0.20	0.20	0.25	0.25	0.30

Clamping Instructions

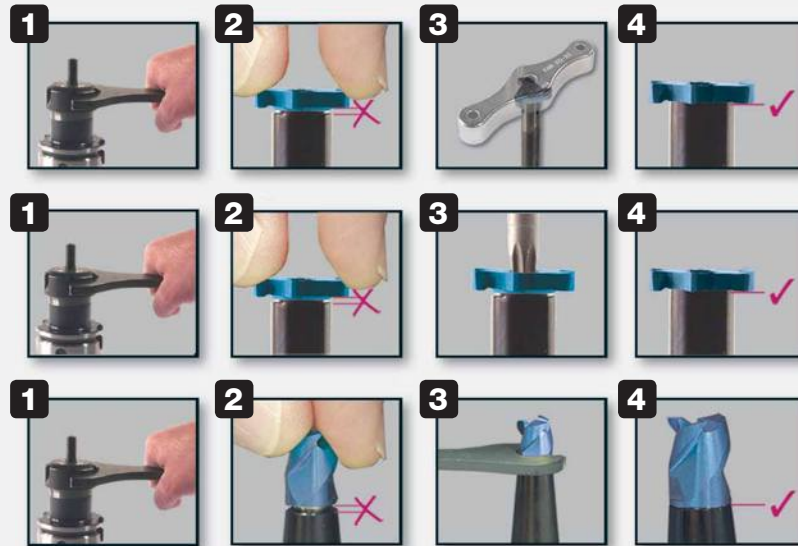

- Use TaeguTec cutting heads only
- Before mounting, clean the connection area of both the head and the holder
- Do not apply lubricant onto the connection areas
- Use the correct TT designated wrench (sold separately)
- Apply the proper clamping torque listed in this guide; excessive tightening may cause the cutting head to break