

NPN

New Product News



CHASE VQUAD FIXED POSITIONING

Extended Flute Cutter Line for Difficult-to-Cut Machining

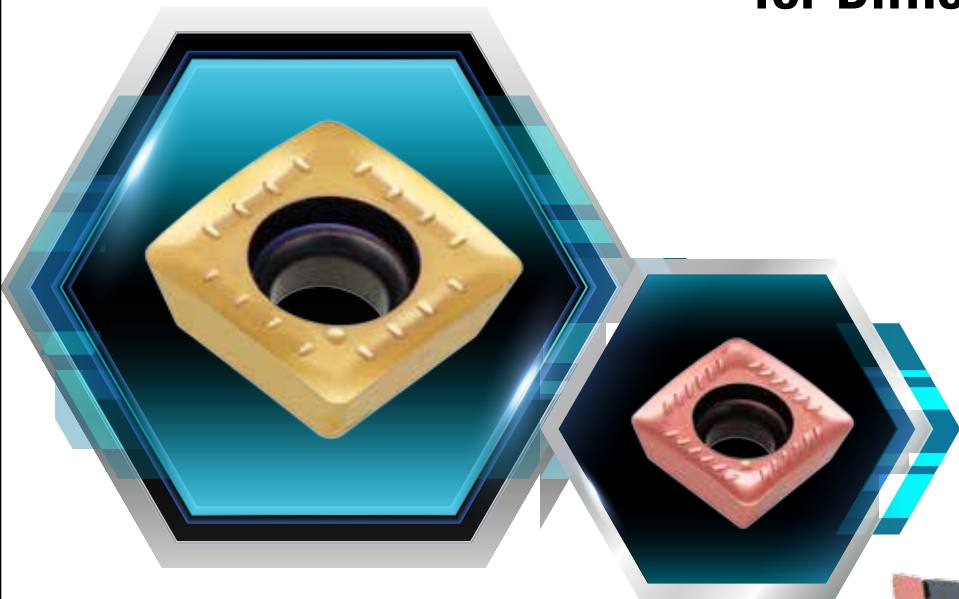

KEY POINT

TaeguTec has released a new extended flute cutter line suitable for difficult-to-cut materials and super alloys.

With the dominance in demand for titanium and heat resistant alloys (HRSA) in the aerospace industry, as seen in recently developed components using high density titanium alloys such as Ti-10-2-3 or Ti-5-5-5-3 to reduce weight, these high strength titanium alloys and heat resistant materials can be difficult to machine, hence affecting productivity.

Cutting tool manufacturers, therefore, require higher productivity tool life solutions for difficult-to-cut materials. The **CHASE-V-QUAD** by TaeguTec meets such demands.

The new line ensures excellent performance in various heat-resistant alloys, titanium alloys, austenitic stainless steel, duplex as well as PH series stainless steel materials.

For further technical questions, please contact TaeguTec's product manager.

Features

- Positive type four corner insert featuring convex cutting edges means smooth machining and minimizes mismatch

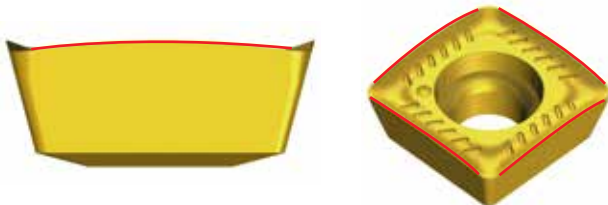

- Unique V-shaped insert bottom design
 - Improved self-positioning for strong insert clamping

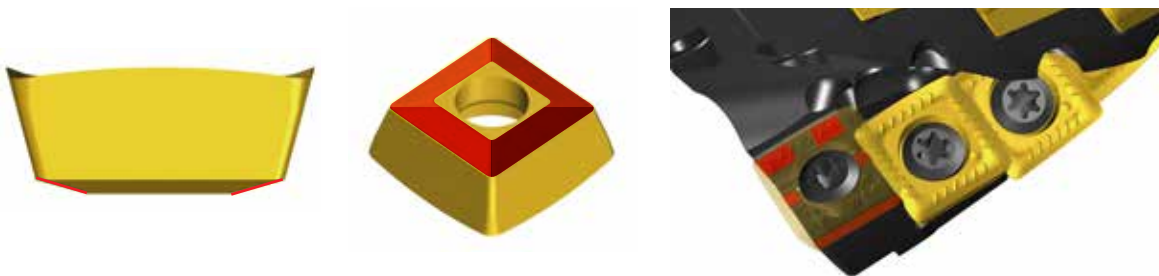

- Cutter's fine-pitch design maximizes productivity and gets smooth chip evacuation because of the insert's V-shaped design which results in the removal of the cutter body's support area

CHASE-V-QUAD



Z=5

Competitor



Z=4



Z=4

Diameter	No. of flutes	
	CHASE-V-QUAD	Similar sized competitor products
Ø32	2	2
Ø40	3	3
Ø50	4	3
Ø63	5	4
Ø80	6	5

- Direct injection of high-pressure coolant from all pockets
 - Excellent chip evacuation
 - Increased tool life and stability



- High rake angle design with convex cutting edges for reduced cutting load and smooth cutting
- Minimizes mismatch



- Unequal placement of inserts minimizes vibration
 $\alpha \neq \beta \neq \gamma$

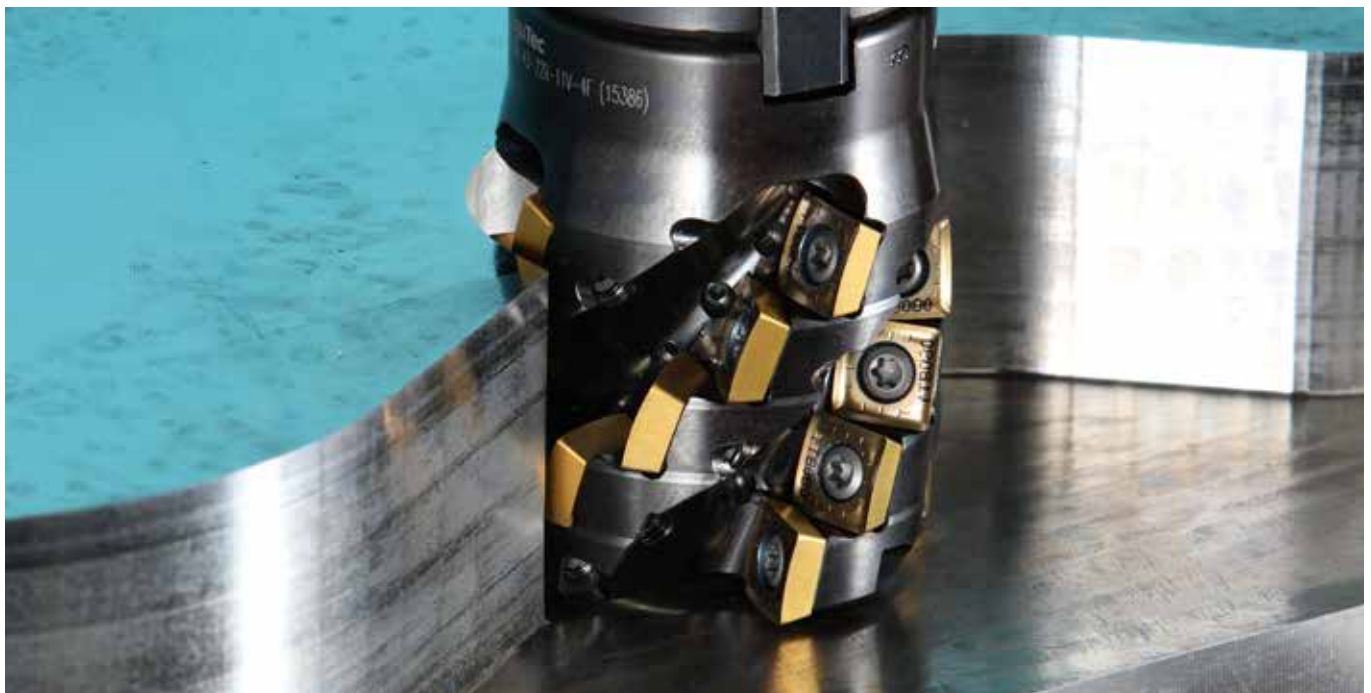
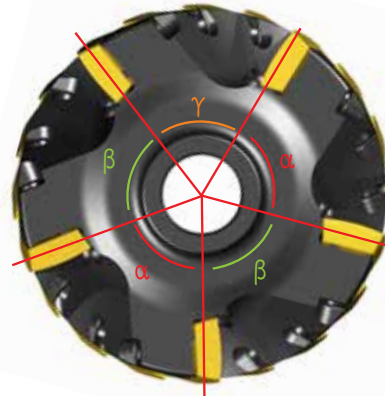

4S-TES-11V

Extended flute cutters

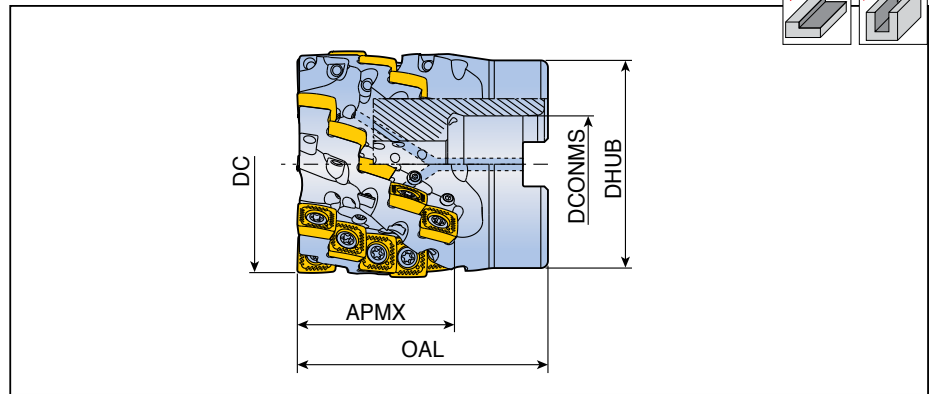
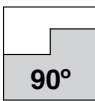

Designation	No. of insert	Dimension (mm)						Coolant	Arbor type	Kg	Mounting bolt	Insert
		DC	DCONMS	DHUB	OAL	APMX						
4S-TES-D40-27-16R-11V-3F	3	9	40	16	38	55	27	●	A	0.3	SH M8x40	SVK(H)T 1145...
D50-43-22R-11V-4F	4	20	50	22	45	65	43	●	A	0.6	SH M10x50	
D50-69-22R-11V-4F	4	32	50	22	45	90	69	●	A	0.8	SH M10x80	
D63-60-27R-11V-5F	5	35	63	27	58	85	60	●	A	1.2	SH M12x60	
D63-69-27R-11V-5F	5	40	63	27	58	93	69	●	A	1.4	SH M12x80	
D80-76-32R-11V-6F	6	54	80	32	76	100	76	●	A	2.6	SH M16x80	

Spare parts

Designation	Screw	Wrench	Wrench handle	Coolant Nozzle	
4S-TES-11V	TS 40093I/HG	TBLD T15-W6	SW6-T	SS 3003-06C	

4S-TEF-11V

Extended flute cutters

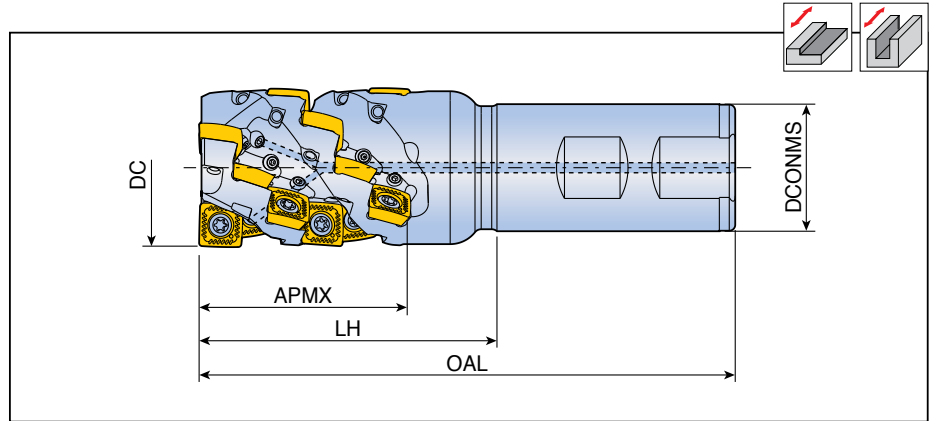
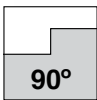

Designation	⊙	No. of insert	Dimension (mm)					Coolant	Insert
			DC	DCONMS	OAL	LH	APMX		
4S-TEF- D32-52-W32-11V-2F	2	12	32	32	135	70	52	●	SVK(H)T 1145...
D40-52-W32-11V-3F	3	18	40	32	135	75	52	●	
D40-60-W32-11V-3F	3	21	40	32	180	85	60	●	
D50-52-W40-11V-4F	4	24	50	40	145	75	52	●	
D50-77-W40-11V-4F	4	36	50	40	170	100	77	●	

Spare parts

Designation	Screw	Wrench	Wrench handle	Coolant Nozzle	
4S-TEF-11V	TS 40093I/HG	TBLD T15-W6	THND 6W	SS 3003-06C	

SVK(H)T



Inserts

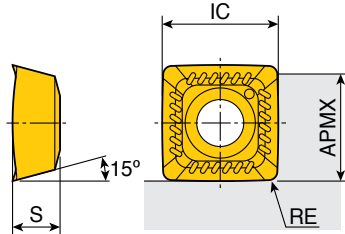

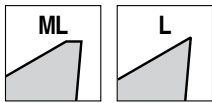

Size	Dimension (mm)			
	IC	S	APMX	RE
114508	11	4.5	10	0.8
114516	11	4.5	9	1.6



Insert	Designation	Recommended machining conditions		Coated								Uncoated				
		ap (mm)	Feed (mm/tooth)	TT9080	TT9030	TT8080	TT8020	TT8525	TT7080	TT7515	TT6080	TT9540	TT3540	K10		
	SVKT 114508-ML	10.0	0.15-0.04	●		●							○	○		
	114516-ML	9.0	0.15-0.04	●		●										
	SVKT 114508-L	10.0	0.12-0.03	●		●										
	SVHT 114508-L	10.0	0.12-0.03	●		●										

- : Standard items
- : Tailor-made items
(produced upon request only)

Cutter options

Option	SVK(H)T
<p>Arbor connected type</p>	<p>①</p> 
<p>Arbor integral type</p>	<p>②</p> 

- Option 1: Standard item
- Option 2: Tailor-made items