

NPN

New Product News



MILLRUSH

POSITIVE 90° MILL

New End Mills for Chamfering



KEY POINT

TaeguTec has added chamfering end mills to the MILL-RUSH family.

To further diversify the use of the MILL-RUSH family, TaeguTec has added internal, external chamfering and deburring end mills to the line. For more information, please contact the product manager.

Features

- Available in three types: weldon shank, cylindrical shank and modular head
- Available in diameter ranges from $\varnothing 3.3$ ~ $\varnothing 21.3$ mm

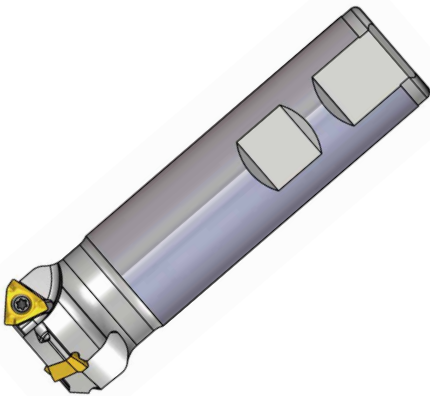

z = 3
Weldon shank and cylindrical shank
30°, 45° and 60° chamfering

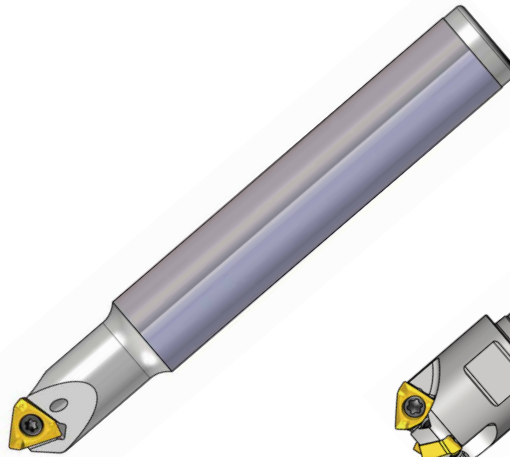

z = 1
Cylindrical shank
Small diameter 45° chamfering

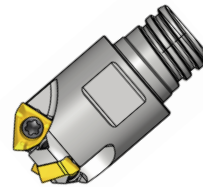

z = 3
Modular head type
45° chamfering



3P-TCF-06/10

End mills

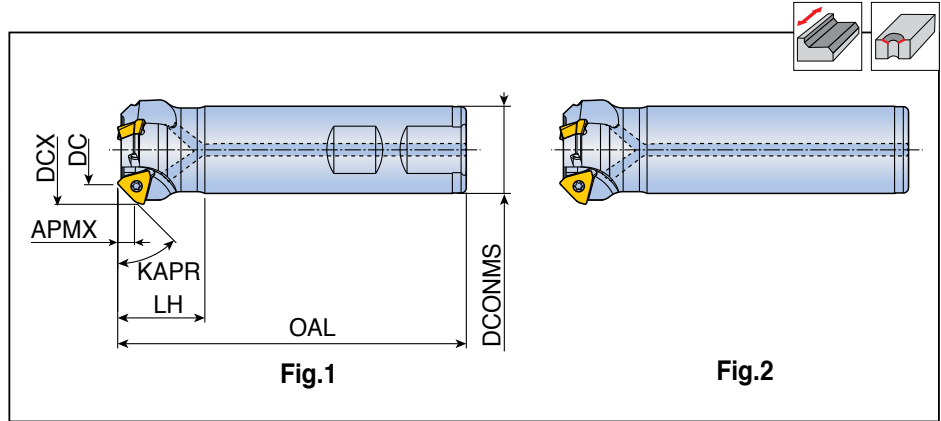
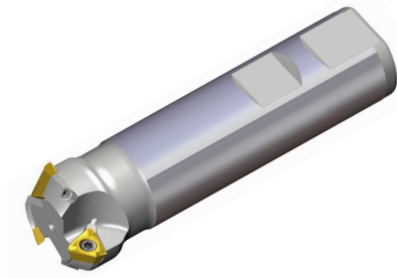

Designation	⊙	Dimension (mm)							Coolant hole	Fig.	Application range(mm)	Insert
		KAPR	DCX	DC	DCONMS	OAL	LH	APMX				
3P-TCF 45-309-12-06	3	45°	16.7	9	12	100	17	3.0	●	2	Ø10.3-Ø14.4	3PK(H)T 0603...
60-320-W25-10	3	60°	27.3	20	25	100	25	5.9	●	1	Ø21.3-Ø26.2	3PK(H)T 1004...
45-320-W25-10	3	45°	31.2	20	25	100	25	4.8	●	1	Ø21.3-Ø28.9	
30-320-W25-10	3	30°	34.5	20	25	100	25	3.3	●	1	Ø21.3-Ø31.0	

Spare parts

Designation	Screw	Wrench			
3P-TCF-06	TS 20043I/HG-P	TD 6P			
3P-TCF-10	TS 25C065I/HG	TD 8			

3P-TCF45-10-L110



End mills

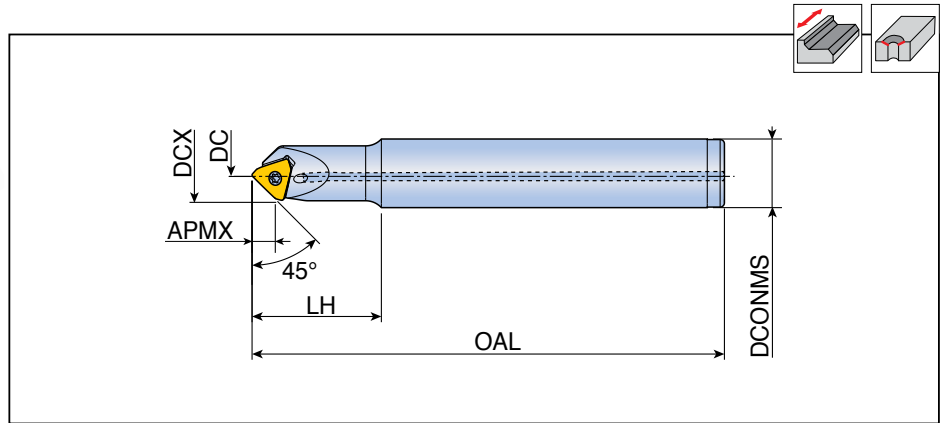
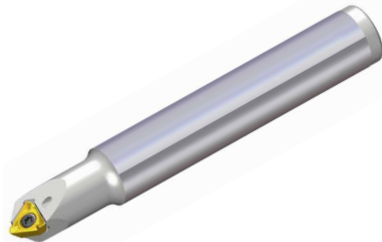

Designation	✳	Dimension (mm)						Coolant hole	Application range(mm)	Insert
		DCX	DC	DCONMS	OAL	LH	APMX			
3P-TCF 45-D2-16-10-L110	1	13.3	2	16	110	30	4.7	●	Ø3.3-Ø10.6	3PK(H)T 1004 ...

Spare parts

Designation	Screw	Wrench			
3P-TCF45-10-L110	TS 25C065I/HG	TD 8			

3P-TCF45-S-04



End mills

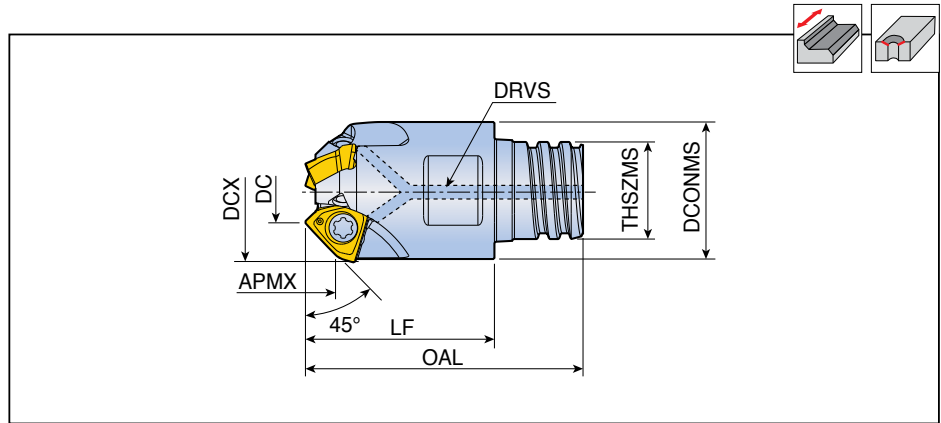

Designation	Flutes	Dimension (mm)								Coolant hole	Application range(mm)	Insert
		DCX	DC	DCONMS	LF	OAL	THSZMS	APMX	DRVS			
3P-TCF 45-306-S08-04	3	12.3	6	11.6	16	23.5	S08	2.5	10	●	Ø7.3-Ø10.5	3PK(H)T 0402...

Spare parts

Designation	Screw	Wrench			
3P-TCF45-S-04	TS 18033/HG-P	TD 6P			