

NPN

New Product News



MAXIRUSH

Introducing Insert Type Modular Heads for MAXI-RUSH Shanks



CHASEMILL



TANGSPEED
TANGENTIAL MILL



NANRUSH
HIGH FEED MILL

KEY POINT

TaeguTec has introduced insert type modular heads for the MAXI-RUSH line of shanks.

The insert type modular heads of the TANG-SPEED, CHASE-MILL and NAN-RUSH products have been incorporated into the flexible MAXI-RUSH line in order to further diversify the popular line's application range. Due to their easy indexable head replacement of the shank mounted to the chuck, the additions to the line offer superior performance, improved productivity and reduced set-up time. For more information, please contact the product manager.

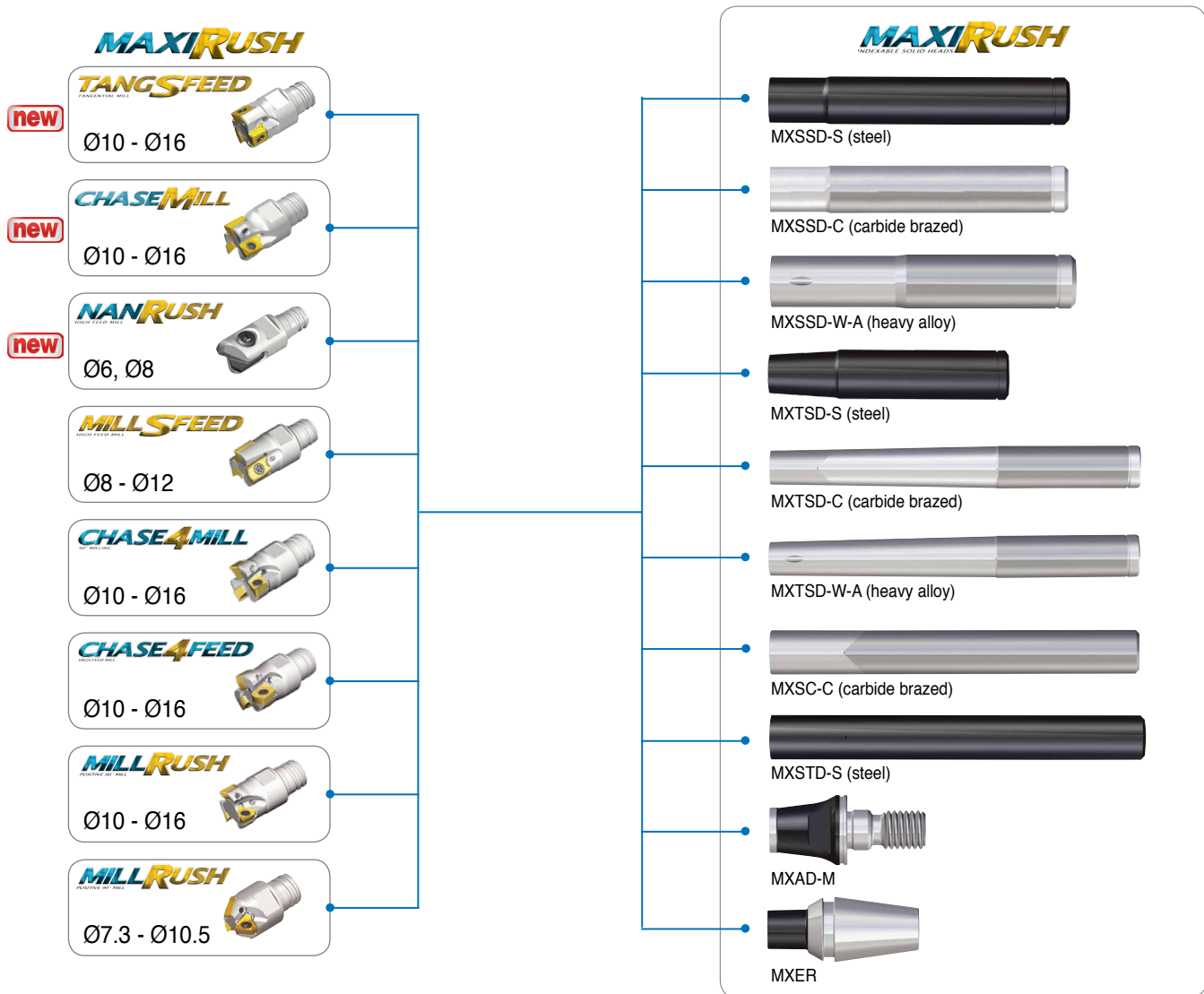

4T-TE90-S-05



Modular heads

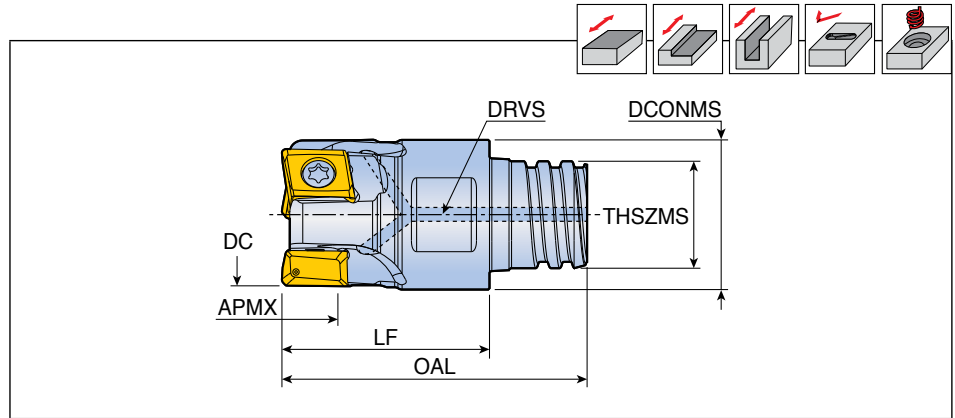
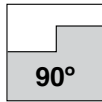

| Designation | | Dimension (mm) | | | | | | | | Coolant hole | Insert |
|----------------------------|---|----------------|--------|----|------|--------|------|------|---|--------------|--------|
| | | DC | DCONMS | LF | OAL | THSZMS | APMX | DRVS | | | |
| 4T-TE90- 210-S06-05 | 2 | 10 | 9.6 | 15 | 21.3 | S06 | 4.6 | 8 | ● | LPK(H)U 05 | |
| 312-S08-05 | 3 | 12 | 11.5 | 16 | 23.5 | S08 | 4.6 | 10 | ● | | |
| 416-S10-05 | 4 | 16 | 15.2 | 20 | 31.3 | S10 | 4.6 | 13 | ● | | |
| | | | | | | | | | | | |
| | | | | | | | | | | | |
| | | | | | | | | | | | |
| | | | | | | | | | | | |
| | | | | | | | | | | | |
| | | | | | | | | | | | |
| | | | | | | | | | | | |
| | | | | | | | | | | | |
| | | | | | | | | | | | |
| | | | | | | | | | | | |
| | | | | | | | | | | | |
| | | | | | | | | | | | |
| | | | | | | | | | | | |
| | | | | | | | | | | | |
| | | | | | | | | | | | |
| | | | | | | | | | | | |

• Matched with MAXI-RUSH holder

Spare parts

| Designation | Screw | Wrench | | | |
|-------------|-------------------|----------------|-------|--|--|
| | 4T-TE90-05 | TS 180411/SG-P | TD 6P | | |
| | | | | | |
| | | | | | |
| | | | | | |

TE90AX-S-06

CHASEMILL MAXIRUSH

Modular heads

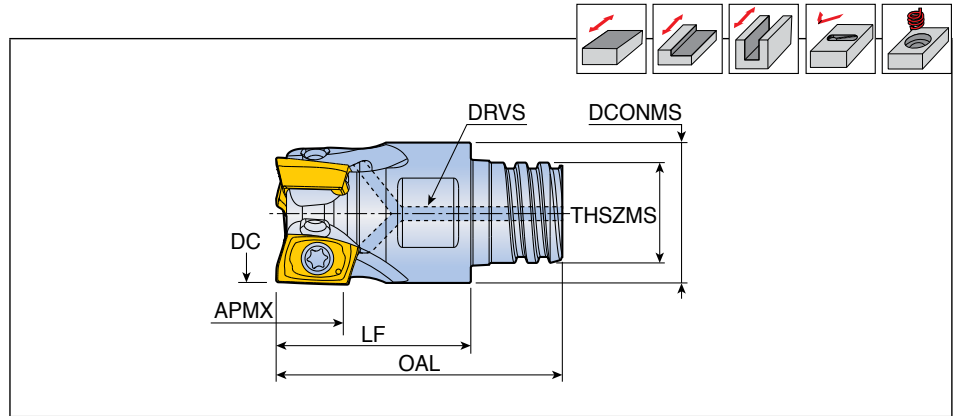
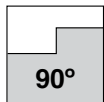

| Designation | Flutes | Dimension (mm) | | | | | | | | Coolant hole | Insert |
|--------------------------|--------|----------------|--------|----|------|--------|------|------|---|--------------|--------|
| | | DC | DCONMS | LF | OAL | THSZMS | APMX | DRVS | | | |
| TE90AX 210-S06-06 | 2 | 10 | 9.6 | 15 | 21.3 | S06 | 5.5 | 8 | ● | AXM(C)T 06 | |
| 312-S08-06 | 3 | 12 | 11.5 | 16 | 23.5 | S08 | 5.5 | 10 | ● | | |
| 416-S10-06 | 4 | 16 | 15.2 | 20 | 31.3 | S10 | 5.5 | 13 | ● | | |
| | | | | | | | | | | | |
| | | | | | | | | | | | |
| | | | | | | | | | | | |
| | | | | | | | | | | | |
| | | | | | | | | | | | |
| | | | | | | | | | | | |
| | | | | | | | | | | | |
| | | | | | | | | | | | |
| | | | | | | | | | | | |
| | | | | | | | | | | | |
| | | | | | | | | | | | |
| | | | | | | | | | | | |
| | | | | | | | | | | | |
| | | | | | | | | | | | |
| | | | | | | | | | | | |
| | | | | | | | | | | | |
| | | | | | | | | | | | |
| | | | | | | | | | | | |

- Cutter body for 'AXMT 06' insert with corner radius more than 1.0mm should be modified accordingly
body "RE"=Insert "RE"-0.1mm
- Matched with MAXI-RUSH holder

Spare parts

| Designation | Screw | Wrench | | | |
|------------------|-------------|--------|--|--|--|
| | | | | | |
| TE90AX-06 | TS 18041/HG | TD 6P | | | |
| | | | | | |
| | | | | | |
| | | | | | |
| | | | | | |

THFN-S



High feed modular heads

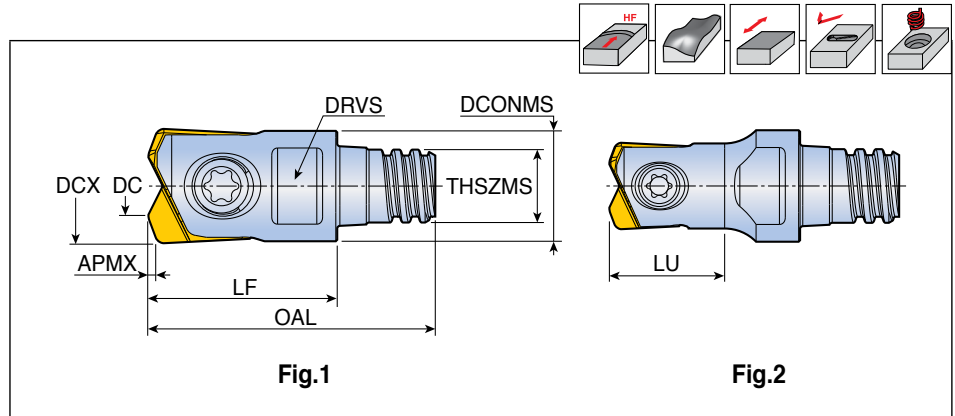

| Designation | ⊙ | Dimension (mm) | | | | | | | | | Coolant hole | Fig. | Insert |
|---------------------|---|----------------|----|--------|----|-----|------|--------|------|------|--------------|------|---------|
| | | DCX | DC | DCONMS | LF | LU | OAL | THSZMS | APMX | DRVS | | | |
| THFN 060-S05 | 2 | 6 | 3 | 7.6 | 13 | 7.8 | 19.7 | S05 | 0.3 | 5.5 | X | 2 | HFN 060 |
| THFN 080-S05 | 2 | 8 | 4 | 7.6 | 13 | - | 19.7 | S05 | 0.5 | 5.5 | X | 1 | HFN 080 |
| | | | | | | | | | | | | | |
| | | | | | | | | | | | | | |
| | | | | | | | | | | | | | |
| | | | | | | | | | | | | | |
| | | | | | | | | | | | | | |
| | | | | | | | | | | | | | |
| | | | | | | | | | | | | | |
| | | | | | | | | | | | | | |
| | | | | | | | | | | | | | |
| | | | | | | | | | | | | | |
| | | | | | | | | | | | | | |
| | | | | | | | | | | | | | |
| | | | | | | | | | | | | | |
| | | | | | | | | | | | | | |
| | | | | | | | | | | | | | |
| | | | | | | | | | | | | | |
| | | | | | | | | | | | | | |

• Matched with MAXI-RUSH holder

Spare parts

| Designation | Screw | Wrench | | Wrench handle | |
|-----------------|------------|--------|-------------|---------------|--|
| | | | | | |
| THFN 060 | TS 20F060A | TD 6 | - | - | |
| THFN 080 | TS 25F080A | - | TBLD T08-W4 | THND 4W | |
| | | | | | |
| | | | | | |
| | | | | | |